



Installation and Operation Manual

Containment Cooling®

EC6001C

Issued February 2015

Contact Geist Global for updates

Geistglobal.com

Opengate Data Center Containment Cooling Circuit

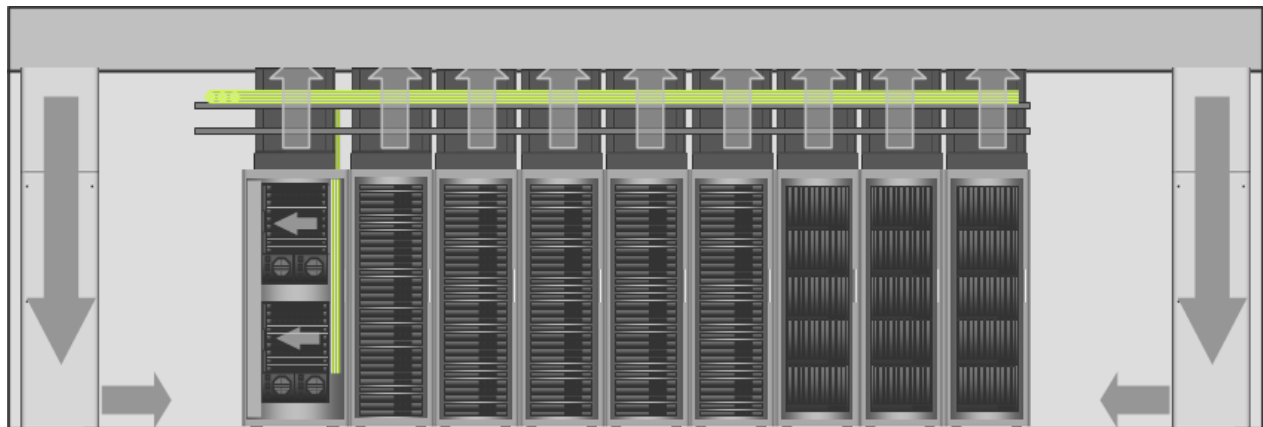

Please note the information contained herein is for informational purposes only. Technical claims listed depend on a series of technical assumptions. Your experience with these products may differ if you operate the products in an environment, which is different from the technical assumptions. Geist reserves the right to modify these specifications without prior notice. Geist makes no warranties, express or implied, on the information contained in this document.

Geist 1821 Yolande Ave., Lincoln, NE 68521
800.432.3219 | 402.474.3400 | F: 402.474.4369 | geistglobal.com



GM1110 Rev. Date 2/24/2015

Table of Contents

Important Safety Information	2
System Description & Components.....	3
Specifications.....	5
Parts List	5
Tools Needed for Installation	6
Equipment Cabinet Requirements.....	6
Product Installation Procedure	6
System Reporting.....	12
Connecting to the Network and Configuring Notifications.....	16
Rack Enclosure & Airflow Inspection Guidelines.....	25
Frequent Asked Questions.....	27



Important Safety Information



- Take care not to drop any foreign objects into the air duct during installation and operation.
- Connect the equipment to a properly grounded three-wire AC outlet.
- The equipment relies on the building installation for protection from over current. A listed 20 amp circuit breaker is required in the building installation.
- Do not attempt to disassemble host controller or fan cartridges; there are no user serviceable components inside.
- All work should be performed by trained and authorized personnel only.
- Keep hands, clothing, and jewelry away from moving parts. Check the equipment for foreign objects before starting the equipment.
- Do not wear jewelry when working near energized components.

System Description

EC Containment Cooling is a fully redundant, modular and scalable pressure controlled system designed to eliminate bypass and maintain proper rack to IT equipment airflow in a heat containment configuration

- Dual input power with auto-sensing logic
- Auto-sensing 0-10, 0-20 kW or 0-30 kW redundant hot-swappable fan cartridges
- Network capability for remote management and alarm notification through web or SNMP
- Local display of status and alarm conditions
- Floating connectors on host controller accept EC10, EC20 or EC30 fan cartridges
- Modular and tool-less quick-swap enclosure
- All cable connections retained or self-locking
- Factory pre-set controls; install and connect to power for automatic operation
- Web enabled and full SNMP communication for trending and alarms
- EC Containment Cooling with optional Unity Cooling Automates the entire data center cooling circuit

Major System Components



EC System



Active

Sensors control fan speeds to maintain a set temperature in the cabinet.

System Top View

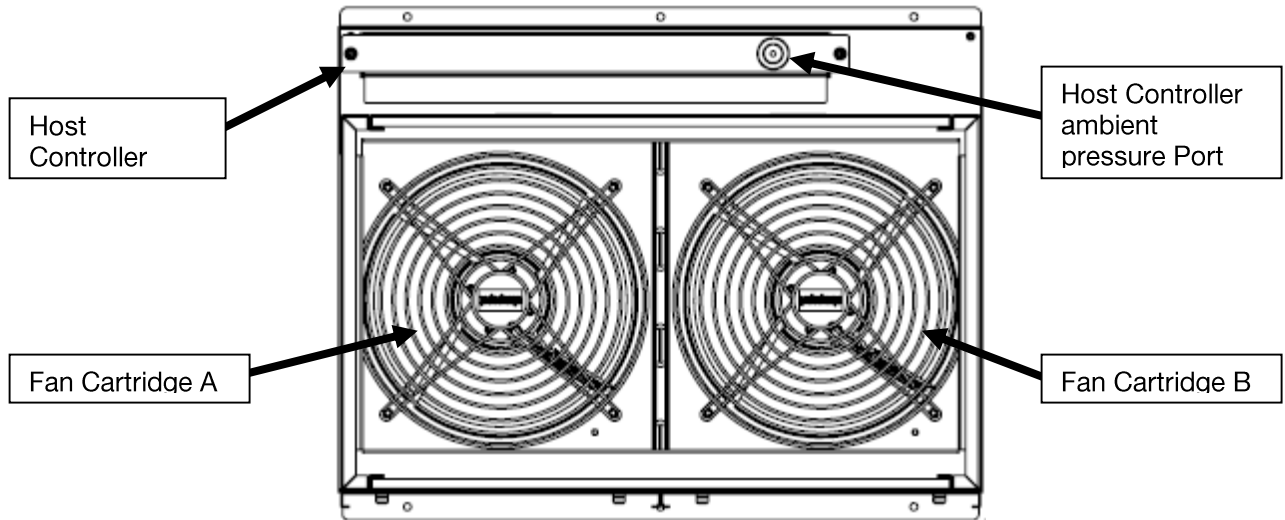

Host Controller

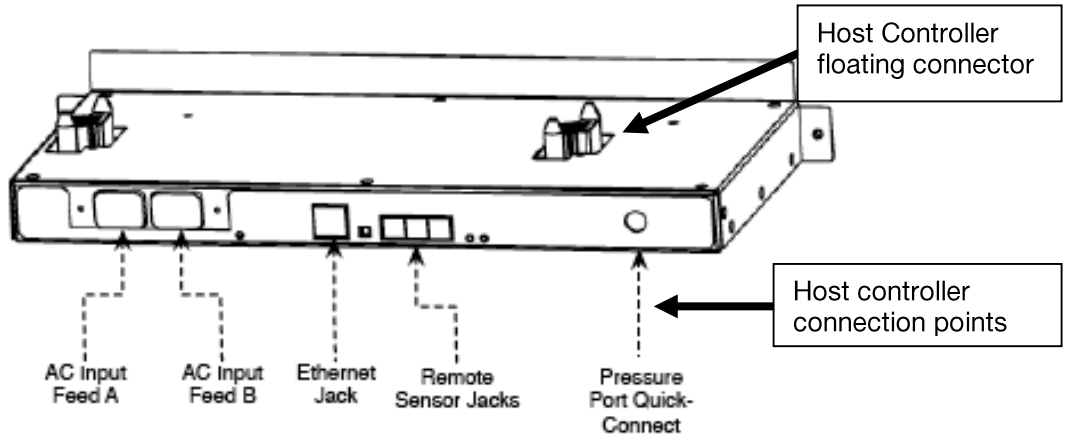

Specifications

Physical	
Dimensions	Standard Chassis: 7.53 H x 23.45 W x 18.93 D inches (191.26 H x 595.63 W x 480.82 D mm) Tall chassis: 11.53 H x 23.45 W x 18.93 D inches (292.86 H x 595.63 W x 480.82 D mm)
Net weight	44 lbs. (20 kg)
Shipping weight	53 lbs. (24 kg)
Electrical	
Input Power	120-208 Volt, 50-60 Hz, single phase or 208-240 Volt, 50-60 Hz single phase
Input Sources	2
Input Power at 208V/230V	EC10: 130 W @ 80%, 230 W @ 100% / 110 W @ 80%, 210 W @ 100% EC20: 155 W @ 80%, 265 W @ 100% / 140 W @ 80%, 250 W @ 100% EC30: 175 W @ 80%, 310 W @ 100% / 165 W @ 80%, 300 W @ 100%
Input Receptacles	IEC-320 C14
Network Settings (default)	
IP Address	192.168.123.123
Subnet Mask	255.255.255.0
Default Gateway	192.168.123.1
Environmental	
Operating conditions	3,000 m max elevation; 0-95% non-condensing humidity; 0-60 degrees C
Storage conditions	15,000 m max elevation; 0-95% non-condensing humidity; -20 to 60 degrees C
Audible noise at 3 feet (1 m)	< 60 dB
Airflow rate	EC10: 1120 CFM max EC20: 2034 CFM max EC30: 2380 CFM max
Conformance	
Approvals	UL, cUL, CE, C-tick, FCC Class A Part 15
Warranty	2 year

Parts List

- 1 EC Chassis
- 2 EC Fan Cartridges
- 1 EC Host
- 4 Interlocking Duct Pieces (ordered separately)
- 1 EC Pressure Sensor Kit
- 1 Hardware Kit - containing fasteners needed for system installation
- Inter-duct Connectors (ordered separately if required)

Tools Needed for Installation

- #2 Philips head screwdriver
- 3/8 in wrench

Equipment Cabinet Requirements

The EC system can be mounted on any equipment cabinet that meets the following requirements:

- Minimum width – 23.6 inches (600mm)
- Minimum depth – 42 inches (1066.8mm)

The EC system utilizes cabinet plenum pressure to control the exhaust fan speed. For proper operation, the equipment enclosure must have a solid rear door, side panels, top panel, bottom panel and front blanking panels for any unoccupied U spaces. Gaskets around the door, bottom or side panels are not required. Brush strips around cabling are recommended.

Product Installation Procedure

Follow these instructions to install the EC Containment Cooling system.

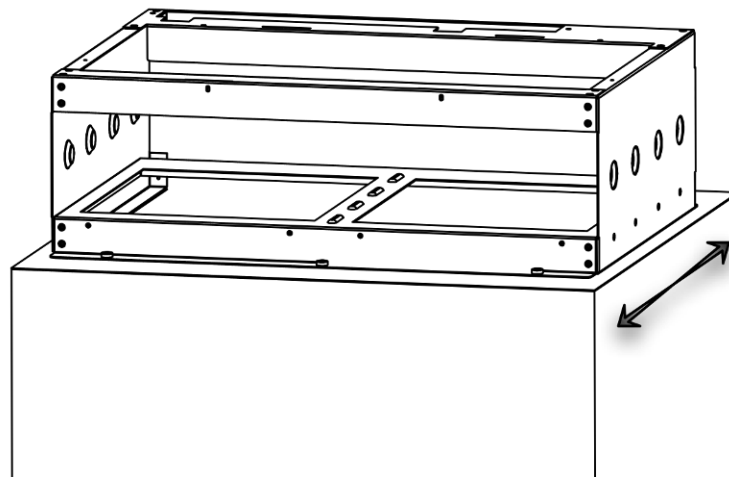

EC Chassis

Positioning the EC System - The EC system mounts on the top the equipment cabinet as shown. The mounting location is user selectable; however optimal performance is achieved when the EC system is positioned at the rear of the cabinet.

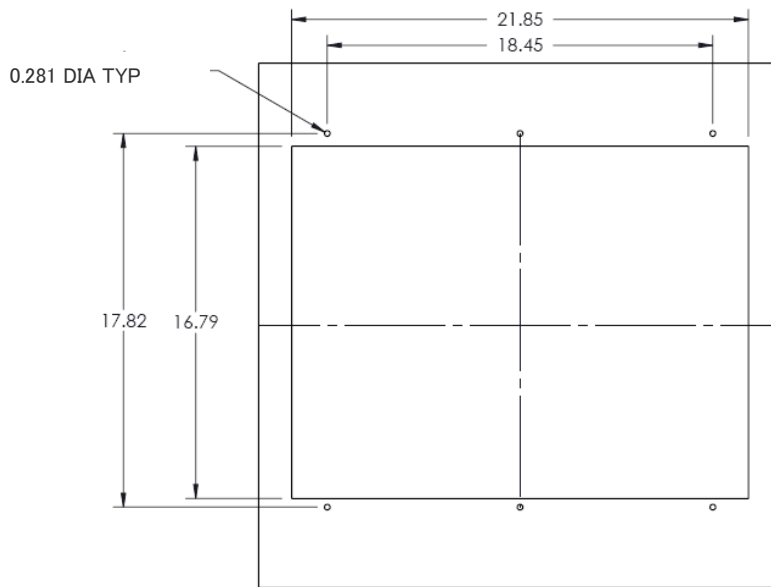

Top Panel Cut Out

Top panel cut out – The top panel of the equipment cabinet will need a pattern cut out of it to allow for the exhaust of hot air, as shown.

For new installations, the Opengate top panel template can be provided to the cabinet manufacturer so that the cut out is made during the fabrication process and is in place upon receipt of the cabinet.

For retrofit installations, replacement top panels with the cut out can be ordered from the cabinet manufacturer or Geist Global.

Mounting the EC chassis on the equipment cabinet

- If the host power and communications module or the fan cartridges are installed, remove them to avoid damage or injury.
- Place the chassis on top of the equipment cabinet with the fan cartridge bays facing the rear door. For shorter duct lengths, the duct can be attached to the chassis before placing the chassis on the rack.
- Align the mounting holes of the chassis with those in the cabinet top panel and attach with the supplied hardware

Exhaust duct assembly – Mounting the exhaust duct to the EC chassis

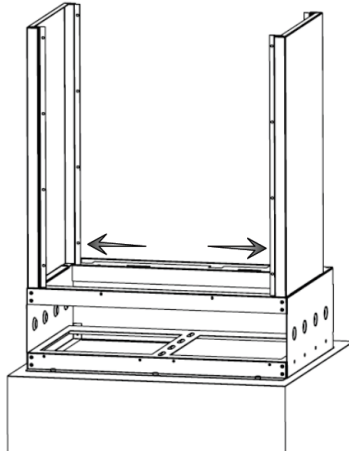

Attaching Exhaust Duct Sides

- Install left and right side panels as shown. Ensure panels snap onto the chassis.

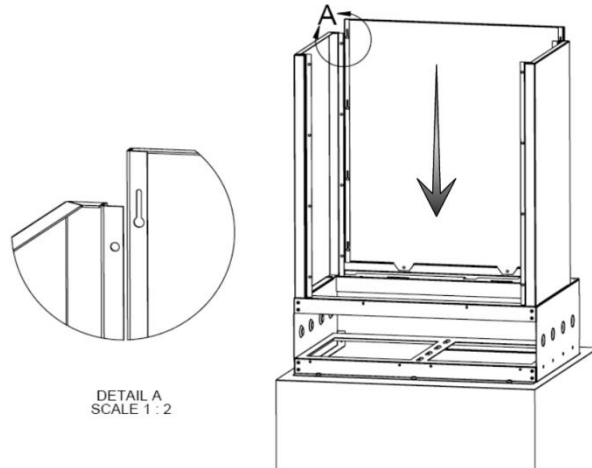

DETAIL A
SCALE 1:2

Attaching Exhaust Duct Panels

- Install duct panel by inserting the captive posts into the eyelet slots of both side panels, as shown. Side panel down until tabs are completely fitted into slots and the lower edge is flush with the chassis.
- Secure panel to chassis by installing the 2 mounting screws (#6-32 x 3/8 black Philips head)

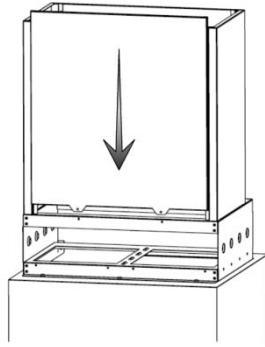

Attaching Exhaust Duct Panel

- Install duct panel by inserting the duct hooks into the slots of both side panels, as shown. Side panel down until tabs are completely fitted into slots and the lower edge is flush with the chassis.
- Secure front panel to chassis by installing the 2 mounting screws (#6-32 x 3/8 black Philips head)

Host Controller installation

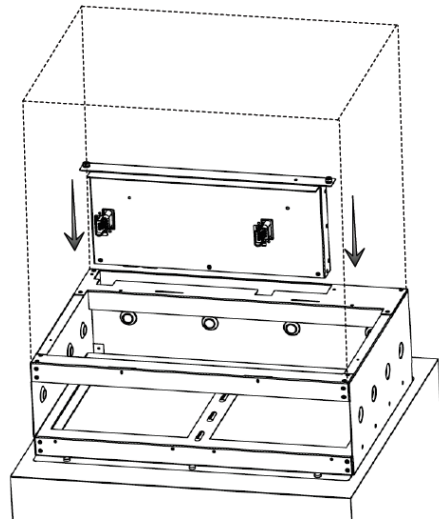

Installing the Host controller

- Insert host power and communications module into EC chassis as shown.
- Secure host power and communications module by tightening the 2 thumbscrews

Fan cartridge installation

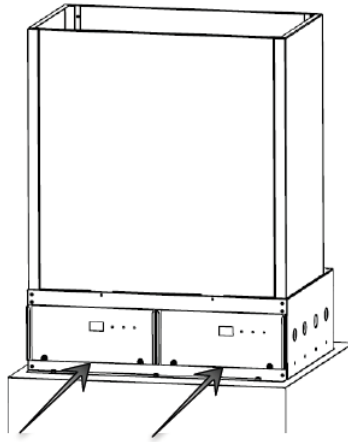

Installing the Fan Cartridges

- Insert fan cartridges into EC chassis as shown.
- Secure fan cartridges by tightening the thumbscrews.

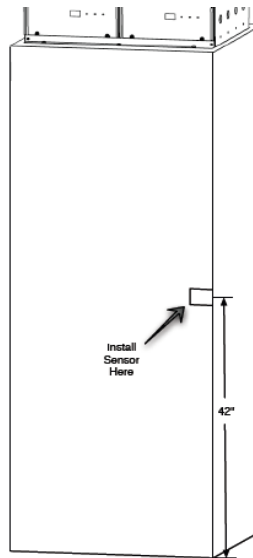

Locating the Pressure Sensor

Sensor hose attachment and installation – The sensor hose is used to communicate the rack plenum pressure to the host module. Mounted on one end of the hose is a quick connect fitting to facilitate ease of installation to the EC Host Controller.

- Locate the end of the sensor hose approximately at the mid-point of the IT load.

- Attach sensor hose to host control module inlet port, as shown.
- Place the sensing end of the hose at the desired location and secure to cabinet with supplied mounting hardware.

Note: Do not remove mechanical baffle from sensor hose as this will affect system performance.

Host Controller Connections – illustrates the EC system connections

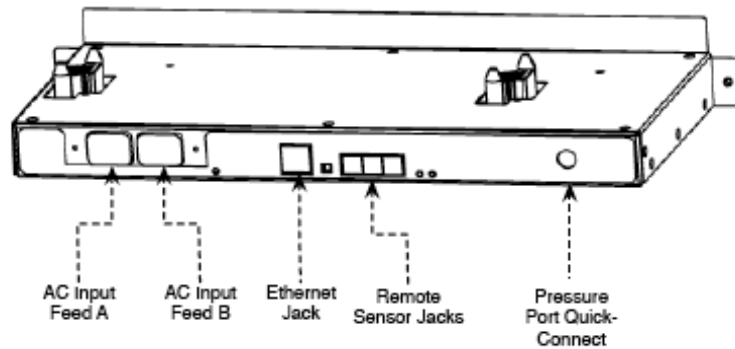

Connecting to the EC Host

Retaining Power Cords on the EC Host

The EC Host includes a power cable retention bracket as shown. The retention bracket is already installed at the factory for your convenience.

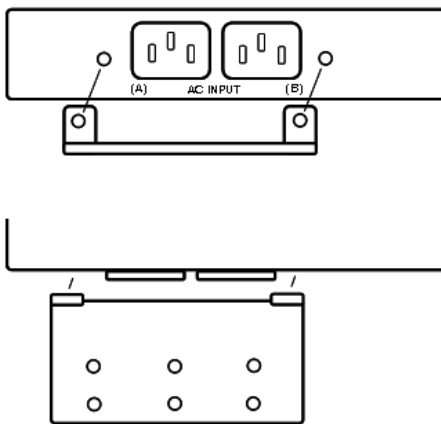

EC Host Power Cable Retention

System Reporting

Front Panel Display

The front panel of each EC Fan Cartridge has 2 display elements, a numeric display and an LED Panel as shown. Each numeric display illuminates cooling capacity in GREEN, to indicate normal operation, cooling capacity or temperature alarm in RED to indicate an alarm condition. Each LED Panel has 3 LEDs that illuminate GREEN to indicate normal conditions, ORANGE to indicate warning conditions and RED to indicate alarm conditions.

Dual Fan Cartridge Front Panels

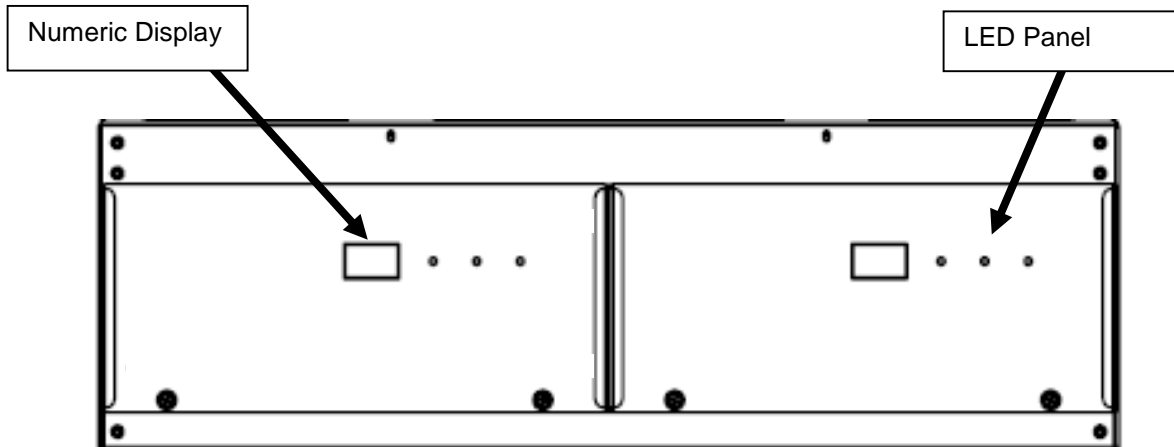

The following table summarizes the fan cartridge front panel display reporting

Numeric Display	GREEN	RED	ALARM ACTION
Cooling Capacity	Within acceptable parameters	Exceeded alarm condition	Increase set point Increase fan size Add EC unit to row
Temperature	Within acceptable parameters	Exceeded alarm condition	Check set points Check rack hot air leak or cool air bypass

LED Panel	GREEN	ORANGE	FLASHING RED	ALARM ACTION
-----------	-------	--------	--------------	--------------

Capacity (cooling)	Within acceptable parameters	Exceeded warning threshold	Exceeded alarm threshold	Increase set point Increase fan size Add EC unit to row
Temp ¹	Within acceptable parameters	Exceeded warning threshold	Exceeded alarm threshold	Check set points Check rack hot air leak or cool air bypass
System	System normal	N/A	1. Loss of A/B Power 2. Missing fan 3. Mismatched fan 4. Fan unit failed 5. Fan unit RPM 6. Fan end of life	1. Check power cord 2. Check fan insertion 3. Use same fan 4. Replace fan 5. Replace fan 6. Order spare fan

(1) Temp LED reports remote temperature, remote humidity or exhaust temperature

Web Interface SiteX View Page

The SiteX View page provides indication of system status using OK in GREEN to green to indicate normal operation, Caution in ORANGE to indicate warning conditions and ALARM in RED to indicate alarm conditions and has two key focal points for information; **SiteX View Summary & Real-time/History Data**

SiteX View Page

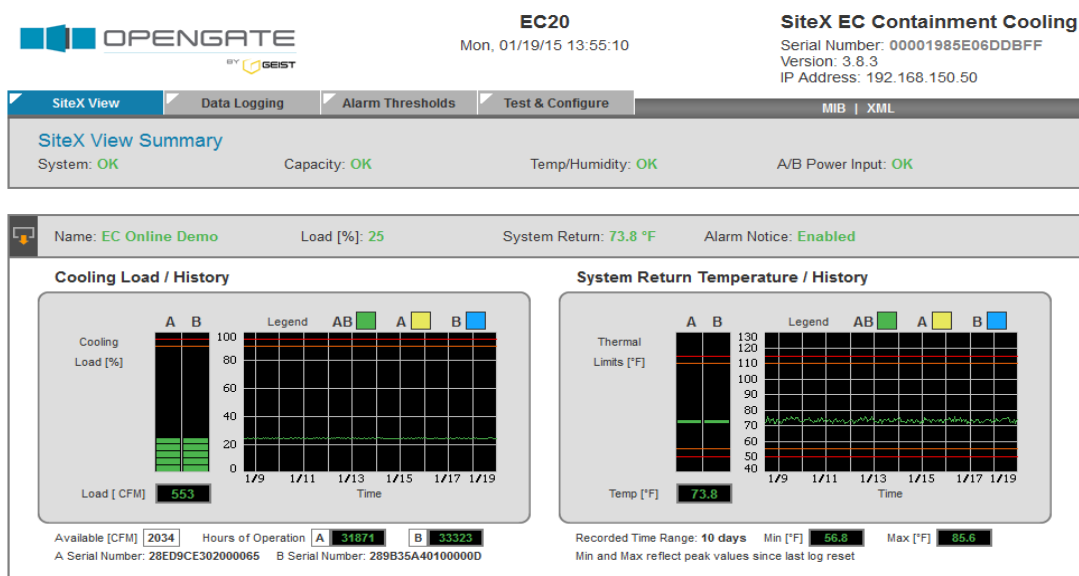

The following table summarizes the SiteX View page reporting

SiteX View Summary	OK (GREEN)	CAUTION (ORANGE)	ALARM (RED)	ALARM ACTION
System	System normal	N/A	1. Loss of A/B Power 2. Missing fan 3. Mismatched fan 4. Fan unit failed 5. Fan unit RPM 6. Fan end of life	1. Check power cord 2. Check fan insertion 3. Use same fan 4. Replace fan 5. Replace fan 6. Order spare fan

Capacity	Within acceptable parameters	Exceeded warning threshold	Exceeded alarm threshold	Increase set point Increase fan size Add EC unit to row
Temp/Humidity ¹	Within acceptable parameters	Exceeded warning threshold	Exceeded alarm threshold	Check set points Check rack hot air leak or cool air bypass
A/B Power Input	Both power feed available	N/A	A Feed or B Feed Only	Check power cord or feed
Real-time/History	VALUE (GREEN)	VALUE (ORANGE)	VALUE (RED)	ALARM ACTION
Cooling Load (capacity)	Value within acceptable parameters	Value exceeded warning threshold	Value exceeded alarm threshold	Increase set point Increase fan size Add EC unit to row
System Return (temp)	Value within acceptable parameters	Value exceeded warning threshold	Value exceeded alarm threshold	Adjust set point Reduce temp by lowering pressure set point
Remote Sensor (temp)	Value within acceptable parameters	Value exceeded warning threshold	Value exceeded alarm threshold	Adjust set point Check rack hot air leak or cool air bypass
Remote Sensor (humidity)	Value within acceptable parameters	Value exceeded warning threshold	Value exceeded alarm threshold	Adjust set point or cooling system

(1) Temp LED reports remote temperature, remote humidity or exhaust temperature

Web Interface Data Logging Page

SiteX EC collects historical data for up to 1 month. All system, capacity and environmental data is logged and can be displayed at various time scales from 15 minutes to 1 month.

Data Logging Page

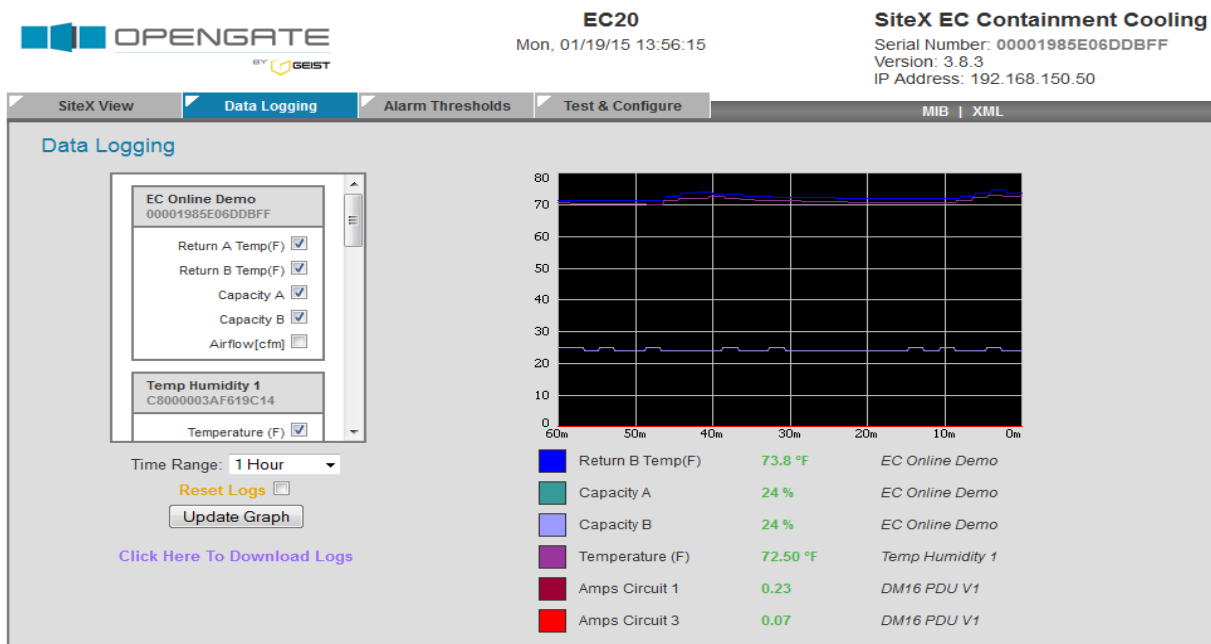

Unit Location: 1717
 Unit Description: Opengate by Geist Demo
 Admin: or Call
 Support: Manuals_support@geistglobal.com or Call 800.432.3219 / +1.402.474.3400
 Copyright © 2008-2014 Geist All Rights Reserved.

The vertical axis units scale adjusts based on the greatest units for a desired checkbox. To achieve greater visibility, select units with the same ranges before updating graph. Selecting checkboxes for viewing does not affect data logging. All data available is logged and kept for the past 1 month. The horizontal axis date scale adjusts based on the latest available data that data has been collected up to 1 month.

The following table summarizes the Data Logging page;

Data Logging	Steps
Viewing Data	Check boxes for the parameters desired and then select Time Range and then select Update Graph .
Download Logs	Select Click Here to Download Logs and save CSV file to a desire location for viewing later
Reset Logs	Select Reset Logs and then select Update Graph . This action will clear all logged data that was available for download and will clear all data from the visible graph.

Connecting to the Network and Configuring Notifications

Default network settings - The Ethernet port will come from Geist Global programmed with the following default settings:

IP Address: 192.168.123.123

Subnet Mask: 255.255.255.0

Default Gateway: 192.168.123.1

- Install a CAT5 Ethernet cable between the EC Host and the computer being used for device configuration. If connecting directly to the EC and not going through a hub, switch or router, a crossover cable may be required.
- To change the default IP configuration, navigate to the 'Test & Configure' page and expand as shown.

The screenshot displays the 'Test & Configure' web page with the following sections:

- System Configuration:** A table of devices with columns for Serial Number, Device Type, and Friendly Name.

Serial Number	Device Type	Friendly Name
00001985E00E99FF	fancontrol	Cab 1 (S-2 beta)
16000003F4CC2114	Temp Humidity	Temp Humidity 1
BA000003F4CB8914	Temp Humidity	Temp Humidity 2
EE0000008759FF12	Temp Humidity	Temp Humidity 3

 Below the table is a checkbox for 'Remove all unplugged devices' and a 'Save Changes' button.
- All Parameters:** A section with a folder icon and the text 'All Parameters'.
- Reboot:** A section with a folder icon and the text 'Reboot'.
- Network:** A section showing current network settings: IP: 192.168.150.220, Subnet: 255.255.255.0, Gateway: 192.168.150.254, DHCP: off. Below this is a form for manual configuration:
 - MAC Address: 00:19:85:E0:0E:99
 - Use DHCP to obtain IP/netmask/gateway:
 - IP Address: 192.168.150.220
 - Subnet Mask: 255.255.255.0
 - Gateway: 192.168.150.254
 - Save Changes button

Test & Configure Web Page

- Enter the desired IP Address, Subnet Mask and Default Gateway information.
- Select 'Save Changes' for the modifications to be accepted and stored in non-volatile memory of the EC Host.
- If the network is running DHCP the EC can have the configuration settings automatically assigned. To enable this feature, select the 'Use DHCP to obtain IP/netmask/gateway' checkbox and save changes.

Note: Recommended practice is to manually program the SiteX EC IP address and 'friendly name' with the physical location or unique identifier during initial installation. Automatic assignment of the IP address via DHCP does not facilitate this process.

Configuring the email and SNMP trap recipient – To receive alarm notifications through email and/or SNMP trap event, navigate to the Test & Configuration web page and expand the E-mail section as shown.

SMTP Server: 64.49.254.24
64.49.254.24

SMTP Port: 25

"From" E-mail Address: dev@opengatedata.com

To E-mail Address 1:

To E-mail Address 2:

To E-mail Address 3:

To E-mail Address 4:

To E-mail Address 5:

POP3 Server:

POP3 Port: 110

Username:

Password:

Save Changes

Configuring Email

To configure email notifications through SMTP enter the IP address of the server hosting the email service into the 'SMTP Server' field (in numeric form). The IP address can be discovered by sending a ping to the email server (e.g. ping mail.geistglobal.com).

- Enter a unique identifier into the 'From E-mail Address' field.
- Identify the individual(s) to receive the email notification by entering his or her address into the 'To E-mail Address' field. Enter only one address per field.

Some email servers require a POP3 connection to be established in order to accept email via SMTP. The last three fields are used for this purpose. Normally, the POP3 IP address will be the same as the SMTP Server IP address.

As shown in the next diagram, configure trap directed notification over SNMP, enter the IP address of the SNMP manager into the 'Trap IP Address' field.

Read Community: public

Listen port for GET: 161

Trap Community: private

Trap IP Address:Port 1:

Trap IP Address:Port 2:

Save Changes

Configuring SNMP

Default Alarm Threshold Settings

SiteX EC is programmed and shipped from the factory with default alarm settings. Alarm threshold values and units can be changed as described in a later section. Following are the default alarm settings:

System Threshold Settings on the Alarm Thresholds Page

System Threshold Settings
Alarm Notice: **Enabled**

Source	Type	Threshold	E-mail	Traps
Capacity	High Alarm	<input type="text" value="95"/>	<input checked="" type="checkbox"/> <input type="checkbox"/> <input type="checkbox"/> <input type="checkbox"/> <input type="checkbox"/>	<input type="checkbox"/> <input type="checkbox"/>
	High Warning	<input type="text" value="90"/>	<input type="checkbox"/> <input type="checkbox"/> <input type="checkbox"/> <input type="checkbox"/> <input type="checkbox"/>	<input type="checkbox"/> <input type="checkbox"/>
Fan End of Service Warning	High Alarm	<input type="text" value="40000"/>	<input type="checkbox"/> <input type="checkbox"/> <input type="checkbox"/> <input type="checkbox"/> <input type="checkbox"/>	<input type="checkbox"/> <input type="checkbox"/>
Return Temp(F)	High Alarm	<input type="text" value="115"/>	<input type="checkbox"/> <input type="checkbox"/> <input type="checkbox"/> <input type="checkbox"/> <input type="checkbox"/>	<input type="checkbox"/> <input type="checkbox"/>
	High Warning	<input type="text" value="110"/>	<input type="checkbox"/> <input type="checkbox"/> <input type="checkbox"/> <input type="checkbox"/> <input type="checkbox"/>	<input type="checkbox"/> <input type="checkbox"/>
	Low Warning	<input type="text" value="55"/>	<input type="checkbox"/> <input type="checkbox"/> <input type="checkbox"/> <input type="checkbox"/> <input type="checkbox"/>	<input type="checkbox"/> <input type="checkbox"/>
	Low Alarm	<input type="text" value="50"/>	<input type="checkbox"/> <input type="checkbox"/> <input type="checkbox"/> <input type="checkbox"/> <input type="checkbox"/>	<input type="checkbox"/> <input type="checkbox"/>

The following table summarizes the System Thresholds Default Settings;

System Threshold Setting	High Alarm	High Warning	Low Warning	Low Alarm
Capacity (%)	95	90	N/A	N/A
Fan End of Service Warning	. Fan cartridges retain their hours of operation even when not powered			
Return Temperature (°F)	115	110	55	50

Return Temp thresholds are widely set to prevent nuisance alarms. After facility operational knowledge, settings can be narrowed to provide valuable information about recirculation of hot air through IT equipment or bypass cooling through IT rack.

Remote Sensor Thresholds Settings on the Alarm Thresholds Page

Remote Sensor: **Top Rack Front**
Alarm Notice: **Enabled**

Sensor ID: 8B000002E01BDD14

Source	Type	Threshold	E-mail	Traps
Temperature (F)	High Alarm	<input type="text" value="90"/>	<input checked="" type="checkbox"/> <input type="checkbox"/> <input type="checkbox"/> <input type="checkbox"/> <input type="checkbox"/>	<input type="checkbox"/> <input type="checkbox"/>
	High Warning	<input type="text" value="80"/>	<input type="checkbox"/> <input type="checkbox"/> <input type="checkbox"/> <input type="checkbox"/> <input type="checkbox"/>	<input type="checkbox"/> <input type="checkbox"/>
	Low Warning	<input type="text" value="64"/>	<input type="checkbox"/> <input type="checkbox"/> <input type="checkbox"/> <input type="checkbox"/> <input type="checkbox"/>	<input type="checkbox"/> <input type="checkbox"/>
	Low Alarm	<input type="text" value="58"/>	<input type="checkbox"/> <input type="checkbox"/> <input type="checkbox"/> <input type="checkbox"/> <input type="checkbox"/>	<input type="checkbox"/> <input type="checkbox"/>
Relative Humidity	High Alarm	<input type="text" value="80"/>	<input type="checkbox"/> <input type="checkbox"/> <input type="checkbox"/> <input type="checkbox"/> <input type="checkbox"/>	<input type="checkbox"/> <input type="checkbox"/>
	High Warning	<input type="text" value="60"/>	<input type="checkbox"/> <input type="checkbox"/> <input type="checkbox"/> <input type="checkbox"/> <input type="checkbox"/>	<input type="checkbox"/> <input type="checkbox"/>
	Low Warning	<input type="text" value="35"/>	<input type="checkbox"/> <input type="checkbox"/> <input type="checkbox"/> <input type="checkbox"/> <input type="checkbox"/>	<input type="checkbox"/> <input type="checkbox"/>
	Low Alarm	<input type="text" value="20"/>	<input type="checkbox"/> <input type="checkbox"/> <input type="checkbox"/> <input type="checkbox"/> <input type="checkbox"/>	<input type="checkbox"/> <input type="checkbox"/>

The following table summarizes the System Thresholds Default Settings;

Remote Sensor Alarm Threshold	High Alarm	High Warning	Low Warning	Low Alarm
Remote Sensor Temp (°F)	90	80	64	58
Remote Sensor Humidity (Rh)	80	60	35	20

Remote Sensor Temperature and **Humidity** high/low alarms are set to the ASHRAE Allowable environment guidelines and high/low warnings are set to the ASHRAE Recommended environment guidelines for IT equipment intake air.

Adjusting System Settings & Enabling Alarms

Notifications in the form of email and SNMP trap events are delivered when an alarm thresholds has been exceeded. Select the desired email or trap notification by checking one or more the boxes to the right of the alarm type and **Save Changes**.

Alarm Threshold Page

System Alarm/Fault Notifications

	E-mail	Traps
A/B Feed Error	<input checked="" type="checkbox"/> <input type="checkbox"/> <input type="checkbox"/> <input type="checkbox"/> <input type="checkbox"/>	<input type="checkbox"/> <input type="checkbox"/>
Fan Cartridge Error	<input checked="" type="checkbox"/> <input type="checkbox"/> <input type="checkbox"/> <input type="checkbox"/> <input type="checkbox"/>	<input type="checkbox"/> <input type="checkbox"/>
Disconnected External Sensor	<input checked="" type="checkbox"/> <input type="checkbox"/> <input type="checkbox"/> <input type="checkbox"/> <input type="checkbox"/>	<input type="checkbox"/> <input type="checkbox"/>

Save Changes

Reset All Alarm Defaults

System Threshold Settings Alarm Notice: **Enabled**

To change threshold values, double click in the value window to highlight the existing value. Type in the new value and then select **Save Changes**.

Remote Sensor: **Top Rack Front** Alarm Notice: **Enabled**

Sensor ID: 8B000002E01BDD14

Source	Type	Threshold	E-mail	Traps
Temperature (F)	High Alarm	90	<input checked="" type="checkbox"/> <input type="checkbox"/> <input type="checkbox"/> <input type="checkbox"/> <input type="checkbox"/>	<input type="checkbox"/> <input type="checkbox"/>
	High Warning	80	<input type="checkbox"/> <input type="checkbox"/> <input type="checkbox"/> <input type="checkbox"/> <input type="checkbox"/>	<input type="checkbox"/> <input type="checkbox"/>
	Low Warning	64	<input type="checkbox"/> <input type="checkbox"/> <input type="checkbox"/> <input type="checkbox"/> <input type="checkbox"/>	<input type="checkbox"/> <input type="checkbox"/>
	Low Alarm	58	<input type="checkbox"/> <input type="checkbox"/> <input type="checkbox"/> <input type="checkbox"/> <input type="checkbox"/>	<input type="checkbox"/> <input type="checkbox"/>
Relative Humidity	High Alarm	80	<input type="checkbox"/> <input type="checkbox"/> <input type="checkbox"/> <input type="checkbox"/> <input type="checkbox"/>	<input type="checkbox"/> <input type="checkbox"/>
	High Warning	60	<input type="checkbox"/> <input type="checkbox"/> <input type="checkbox"/> <input type="checkbox"/> <input type="checkbox"/>	<input type="checkbox"/> <input type="checkbox"/>
	Low Warning	35	<input type="checkbox"/> <input type="checkbox"/> <input type="checkbox"/> <input type="checkbox"/> <input type="checkbox"/>	<input type="checkbox"/> <input type="checkbox"/>
	Low Alarm	20	<input type="checkbox"/> <input type="checkbox"/> <input type="checkbox"/> <input type="checkbox"/> <input type="checkbox"/>	<input type="checkbox"/> <input type="checkbox"/>

Save Changes

Configuring notifications and alarm thresholds – Notifications in the form of email and SNMP trap events can be issued when one or more alarm thresholds have been exceeded. To set an alarm threshold and enable notifications, navigate to the 'Alarm Thresholds' web page and expand the System Environmental section, as shown.

Note, the default Capacity and Return Temperature have been selected to comply with ASHRAE standards.

Test & Configure Page

Modify **Friendly Names** to each **Device Type** (system and up to 3 remote sensors) and then select **Save Changes**.

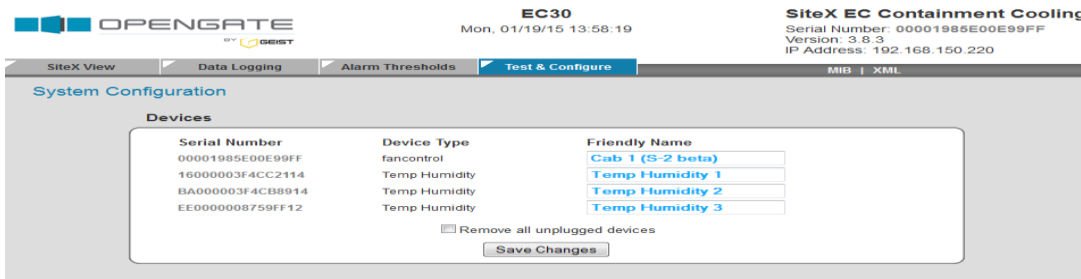

System Clock - Test & Configure Page

Resetting **System Clock** and then select **Save Changes**. Setting clock is necessary for data logging capability. System clock settings are lost after a few weeks of the Host Controller not being powered.

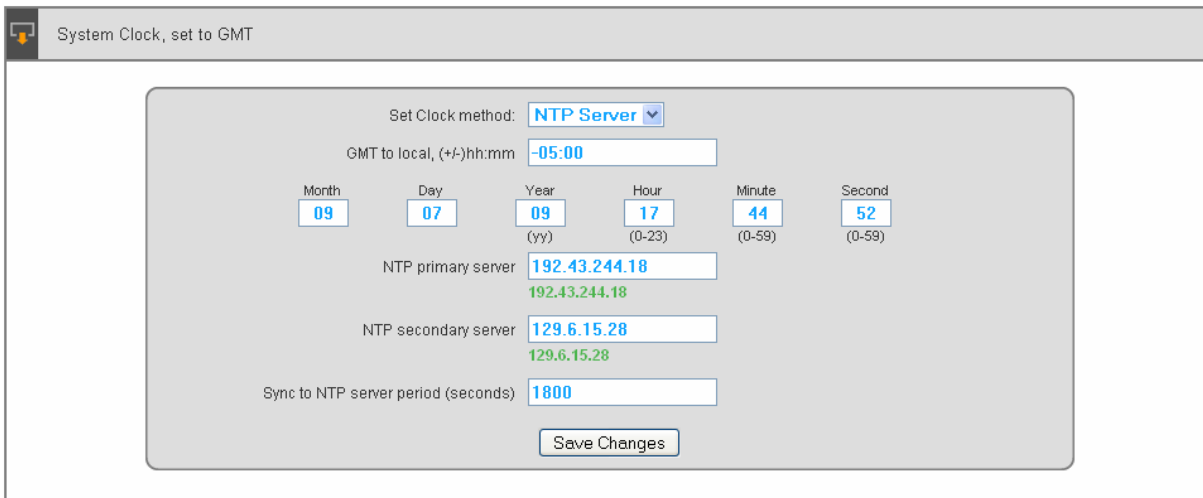

E-mail - Test & Configure Page

Re-assigning **E-mail** with each email address corresponding to each checkbox in the **Alarm Thresholds** page and then select **Save Changes**.

E-mail SMTP: POP3: Authentication: Disabled

SMTP Server:

SMTP Port:

Leaving the POP3 Server blank with the Username/Password filled in and using SMTP Port 465 enables ESMTP/SSL.

"From" E-mail Address:

To E-mail Address 1:

To E-mail Address 2:

To E-mail Address 3:

To E-mail Address 4:

To E-mail Address 5:

POP3 Server:

Leaving the POP3 Server blank with the Username/Password filled in enables ESMTP/TLS. No POP3 Server and no Username/Password enables no authentication.

POP3 Port:

Username:

Password:

SNMP - Test & Configure Page

Re-assigning **SNMP** traps with each trap corresponding to each checkbox in the **Alarm Thresholds** page and then select **Save Changes**.

SNMP Trap 1: Trap 2:

Read Community:

Listen port for GET:

Trap Community:

Write Community:

Trap Type:

Trap IP Address:Port 1:

Trap IP Address:Port 2:



Test E-mail or SNMP - Test & Configure Page

After changing **E-mail** or **SNMP** trap address information select **Send** to test notification.

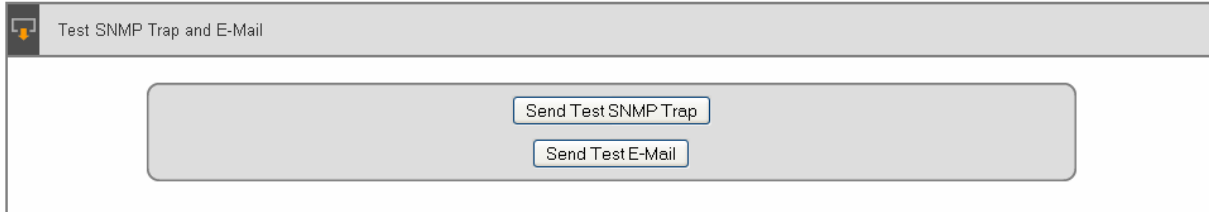

Test SNMP Trap and E-Mail

Send Test SNMP Trap

Send Test E-Mail

Units - Test & Configure Page

Change **Units** to Imperial (Fahrenheit and CFM), Metric (Celsius and MCH) or Imperial/Metric (Celsius and CFM) and then select **Save Changes**.

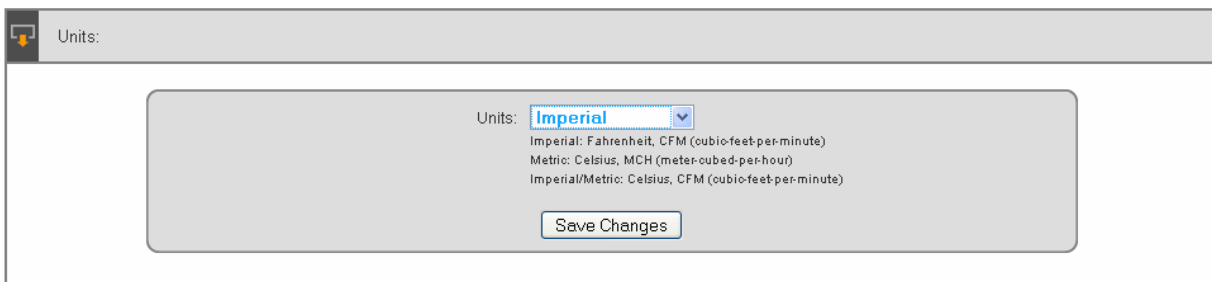

Units:

Units: **Imperial**

Imperial: Fahrenheit, CFM (cubic-foot-per-minute)
Metric: Celsius, MCH (meter-cubed-per-hour)
Imperial/Metric: Celsius, CFM (cubic-foot-per-minute)

Save Changes

Fan Control Settings

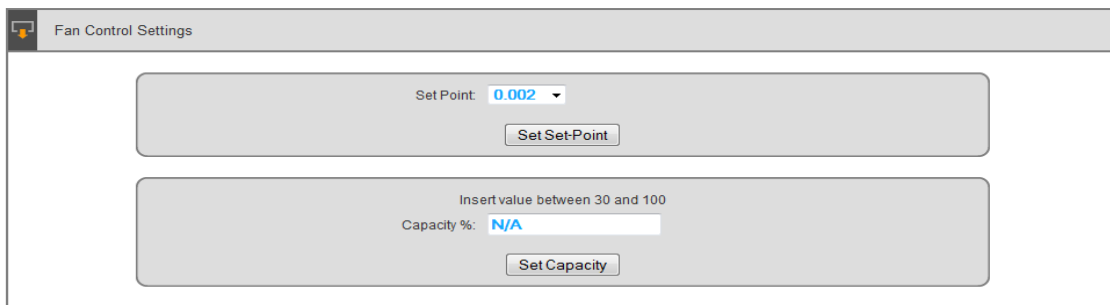

Fan Control Settings

Set Point: **0.002**

Set Set-Point

Insert value between 30 and 100

Capacity %: **N/A**

Set Capacity

The EC fans can be controlled **automatically** by selecting the desired cabinet pressure setting from the Set set-point pull down menu. They can also be controlled **manually** by typing in the desired capacity % setting (from 30 to 100%) in the Set Capacity window.

Setting up Row control for non-partitioned cabinets

Master / Advisor Control Assignment

Set EC Host as Master

Target Pressure Differential 0

Advisor IP Addresses

- 192.168.150.221
- 192.168.150.222
- 192.168.150.223
- 0.0.0.0
- 0.0.0.0
- 0.0.0.0
- 0.0.0.0
- 0.0.0.0
- 0.0.0.0
- 0.0.0.0
- 0.0.0.0

Save Changes

In Row Control mode, adjacent EC units can be set up to work as one unit to work together to control the pressure in commonly joined cabinets. This allows less than one EC per cabinet for controlling airflow in lower density situations. Designate any of the EC units in the row as the “Master”, and then list all other IP addresses of units to be controlled as shown.

Accounts and Passwords

The unit offers account security options that are entered on the *Admin* tab of the *Configuration* page. There are three levels of account security:

Administrator: Password protects the Display, Alarms and Configuration pages.

Control Access: Password protects the Control Actions and Control Settings pages.

View-Only: Password protects the Sensors, PDA, WAP and XML pages.

Name and Password Configuration

NOTE 1: If Account currently has a password, leaving Old Password blank results in no changes to that account.
 NOTE 2: Administrator password may be used in the Old Password field of any account.
 NOTE 3: If setting New Password to blank, Account Name must also be blank.
 NOTE 4: If New Password is not blank, Account Name must not be blank.

Administrator Account Name

If blank, all access is granted without a password.

Old Password

New Password

New Password Again (again, to confirm)

Warning: Record your password. Loss of password may require 48 hours to recover.

Control Account Name

If blank, Control and View Only access is granted without a password.

Old Password

New Password

New Password Again (again, to confirm)

Warning: Record your password. Loss of password may require 48 hours to recover.

View Only Account Name

If blank, View access is granted without a password.

Old Password

New Password

New Password Again (again, to confirm)

Warning: Record your password. Loss of password may require 48 hours to recover.

User account names may include alphanumeric characters, spaces and underscores. Passwords may include alphanumeric characters and underscores.

Note: The Administrator account must be active to enable the Control Access and View-Only accounts.

Note: The Control Access account must be active to enable the View-Only account.

Note: The account names "root" and "admin" are disabled for security reasons and cannot be re-enabled.

Warning: Record your passwords. To reset lost passwords, follow the instructions for resetting the unit's IP address and passwords given in the **Error! Reference source not found.** section. To generate a temporary recovery password to access the unit, contact customer service from a location where the unit can be accessed via the internet.

Admin Information

Information entered in the "Admin Info" section of the *Admin* tab of the *Configuration* page will show up at the bottom of the unit's web interface.

Admin Info

Contact Name:

Contact Email: (sysContact)

Contact Phone:

Device Location: (sysLocation)

Device Description: (sysName)

Fan Fail Test - Test & Configure Page

To determine the operational or environment effects of a single fan failure, select **FAN A** or **FAN B**, enter a **Test Time** in seconds and select **Run Test**. Operating and environment conditions can be observed remotely from the SiteX View or Data Logging page.

Fan Fail Test

Fan:

Test time:

Rack Enclosure & Airflow Inspection Guidelines

Rack Top Panel

Cable entry through the rack top panel should be made through brush strips to prevent cold air bypass into the rack, returning to the cooling units. Openings near the top of the rack will cause the EC units to run at a higher capacity that is required.

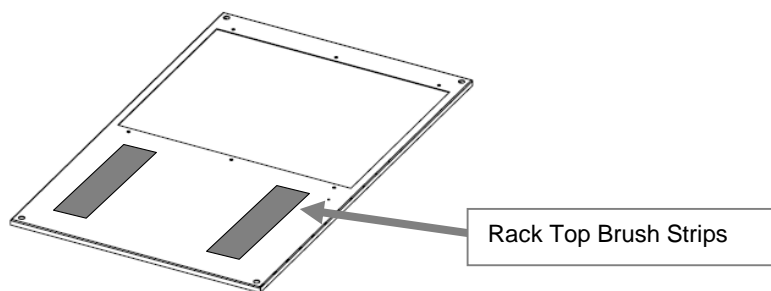

Rack Side Panels and Rear Door

Racks must be deployed with solid side panels and solid rear doors to contain heat and allow pressure control per an individual enclosure.

Rack Front Mounting Rails & Blanking Panels

Racks must be deployed with front rails and blanking panels that do not allow hot air to leak out at the front of the rack. Inspect rack for obvious leakage paths that are larger than 0.25 inches (6mm).

Checking Pressure Sensor Location

The pressure sensor is used to communicate the rack plenum pressure to the host controller module. The pressure sensor should be located at approximately the mid-point of the cabinet. Front-to-rear sensor position with respect to the rear of the IT equipment will not affect operation. Do not mount the pressure sensor at a U height position where there is no IT equipment mounted. This will produce a slightly lower pressure reading and result in a slightly lower capacity than required. Do not mount the pressure sensor at a U height position where there may be a few servers that are excessively deeper than the other servers in the same rack. This will produce a slightly higher pressure reading and result in a slightly higher capacity than required.

EC Capacity Meter Guideline

It is typically normal to have EC systems indicate different capacity for racks with exactly the same IT load.

It is quite common to have two racks with the same IT power load running at different flow rates – hence a different EC capacity. There are multiple reasons for varying airflow rates for the same IT power load. They are; IT equipment intake temperature variation, IT equipment chip temperature variation, IT equipment single power supply failure or excessive rack openings (such as blank panels missing) allowing cool air bypass.

Check the EC intake temperature graphs to rule out intake temperature as the cause. It is important to look at intake temperature at multiple rack heights. IT equipment at the top of the rack could be running higher airflow rates because of a higher temperature there. Often racks at the end of the row can see hot air at the intake – a condition that would only exist if a substantial number of the racks in the data center did not have an EC system installed.

For the same power load, if the intake temperature between two racks is the same but the exhaust temperature is different, it suggests the IT equipment in the rack has a different airflow rate versus the other or there is bypass cooling going through an open U space or through openings at the top panel of the rack, reducing the EC exhaust temperature. Higher IT equipment flow rates for the same power load or bypass cooling will cause the EC capacity to run higher.

If all reasons described here are ruled out, please call customer service.

If the EC capacity keeps increasing when there is no load in the rack you will need to unplug the EC unit or change its pressure set point to a higher value.

The EC system continually adjusts to maintain the set operating pressure. With no load in the rack, the EC system is trying to operate with an infinitely small pressure change. We recommend un-plugging the unit until a load is placed in the rack. In this condition, a small amount of cool air will bypass through the EC units that are off. Also, changing the fan operation pressure set point to a 0.008 positive value will reduce the fan speed.

Frequent Asked Questions

General & Physical Environment Questions

Q: Where do I mount my pressure sensor?

A: The pressure sensor placement is at the rear of the rack located midway top to bottom of the IT equipment stack. For example; with IT equipment stacked to 30U from the bottom, the sensor height would be between 12-18U for accurate capacity operation. The sensor does not have to be directly behind the IT equipment and can be placed off to the side near the cabling or power strips if desired.

Q: What duct length do I need for a 12 foot height from the floor to the drop ceiling?

A: The duct length is calculated by subtracting the rack height and EC Chassis height from the 12 foot space then add 1.5 inches which allows the duct to pass through the drop ceiling by this amount. We have two EC

Chassis heights; the standard is 7.5 inches tall and the EC Tall Chassis is 11.5 inches. *Example; 144 inches (12 foot space) – 84 inches (rack) – 7.5 inches + 1.5 inches = 54 inch duct*

Q: What is the longest duct Geist Global makes and what if I need a longer one?

A: The longest duct we suggest is 72 inches. This would allow a drop ceiling height of 13 feet 10 inches when used with the tall EC Chassis. For ceiling heights above this, you can use a taller rack and/or use the EC Duct Cap that is made to couple with a 20" round duct. This 20" round duct would allow you to go to any ceiling height. See Geist Global's Submittal Drawings for further information.

Q: What types of fans are used in your system? I believe they are DC, but I remember someone asking me a while ago if they were brushless, tube axial, etc.

A: We are using 48V DC Electronically Commutated (EC) fans. Our fans are brushless and have a tube axial configuration.

Q: What is the MTBF of the EC Fans and System?

A: The MTBF is 60K hours for the fan itself, but we conservatively de-rate our system MTBF to 40K hours (4.5 yrs.) based on accepted de-rate rules for electronics.

Cooling and Airflow Management

Q: If I lose one fan, will the remaining fan handle the entire rack airflow requirements?

A: If the EC capacity reading is 50% or less when two fans are operational, then one fan is capable of handling the airflow requirements. The single fan will speed up to compensate for the fan that is off line. However, Geist Global does not recommend sizing the EC for airflow redundancy. The additional overhead for fan power, space required and costs are not justified.

The following is what to expect if one fan fails or is removed from the system.

- Capacity for the remaining fan will approximately double or reach 100% if the two fans were originally operating greater than 50%.
- A slight pressure in the rack will force a small amount of hot air leakage out the front rack rails and bottom of the rack due to this pressure. This is common with any passive system and will not cause issues since this should be the only rack with leakage due to no pressure control.
- The EC will send an alarm when a cartridge fails and a new alarm when the capacity exceeds the set capacity threshold.
- The EC Fan Cartridges can be swapped out while the rack is operational.

Q: We would like to reduce the exhaust temperature of the rack; can we adjust the EC Fan Control setting to a negative pressure to accomplish this?

A: Yes, for example, when you are concerned about high heat return to DX CRAC units. We can control the amount of bypass air by simply changing the negative pressure set point. This pressure setting can be changed remotely and alarm

thresholds can be set so you know if you have exceeded your desired temperature. Simply change the setting and then chart the performance over time.

Q: We would like to pull in cool air along the sides of network switches; can we adjust the EC Fan Control Settings to a negative pressure to accomplish this?

A: This can be accomplished for small 1U or large core switches.

Example for 1U switches; set the EC unit to -0.006 pressure and open a 2U space at the rack front opposite or just below the 1U switch height. Cool air then enters this space and washes across the 1U switch/s. The 2U open space at the front should be filled with the Opengate Vented 2U Blank Panel which is clearly marked so someone doesn't come along and block up the opening. Adjustment to the negative pressure set points can be made to reduce or increase bypass airflow.

Example for large core switches; with the large core switch/s in a 750mm or 30 inch wide rack, make sure the left vertical rack rail is blocked from air bypassing and make sure the right vertical rail is open to allow bypass airflow. Set the EC unit to -0.006 pressure. Cool air then enters this space and washes across the switch/s. Place a remote temp/humidity sensor at the side intake of the core switch and monitor intake temperatures. Adjustment to the negative pressure set points can be made to reduce or increase bypass airflow.

Q: How do I safely raise my supply air temperature to 22-24 °C (72-76 °F) and not cause an increase in server airflow?

A: Opengate EC systems maintain temperatures at all points in the data center within a few degrees of the supply air temperature. Opengate systems also eliminate back pressure on server airflow to improve server fan efficiency.

Many legacy servers and servers shipping today increase their fan speeds at approximately 26°C (79 °F) to improve server cooling at higher intake temperatures. This can more than double, sometime 10X the server fan power consumption. While increased server fan power actually lowers your PUE metric, the overall power consumption in the data center increases significantly. More advanced energy star servers have fan speeds adjustments based on server internal temperatures. Because of this, server fan energy performance will also be subject to rack pressure since the pressure reduces airflow rates, a resulting increased temperature in the server will develop which the server fans will overcome with increased airflow.

Q: Should raising temperatures in data centers be carried out in a systematic manner to best determine where hot spots may occur and to possibly prevent the risk of shutdown because of high temperatures?

A: Due to possible site specific variables and unforeseen infrastructure conditions, it would be a recommended practice to take a systematic approach to raising supply air temperatures. One client had a '2 degree Tuesday' approach, raising his supply air 2 degrees every Tuesday until he was at 23°C. With the Opengate EC system deployed on a substantial percentage of the IT load, there should be no hot spots or hot air contamination of the cool supply air. Geist Global allows you to safely raise the supply air without contamination and also allows the servers to run at minimum internal temperatures due to zero back pressure, allowing the maximum supply air temperature and maximum efficiency.

Q: If I raise the supply air, how much less time do I have if my cooling plant fails?

A: A published Geist Global study shows that at average loads of 5 kW per rack and conventional hot/cold aisle design you raise the temperature 9 °F every 20 seconds. If we are supplying at 74 °F versus 65 °F we would only have an additional 20 seconds. What we sometimes fail to recognize is that an average of 5 kW per rack with no cooling is a high heat load to continue to dissipate.

Opengate cooling circuit significantly increases the time to adapt to cooling circuit failure. With Geist Global, the hot exhaust air is directed to a ceiling plenum return. Fans in the EC units are on UPS power and fans on the CRAC/CRAH units will start again when the generator comes on line (typically 8-12 seconds). Even without a chiller plant providing cooling, the IT heated exhaust air continues to move into the ceiling plenum, across the CRAC/CRAH coils and across the cold floor, giving additional time during cooling plant failure.

Q: I have multiple racks with exactly the same IT load but one EC system indicates a different capacity, is something wrong?

A: It is quite common to have two racks with the same IT load running at different flow rates – hence a different EC capacity. There are multiple reasons IT equipment can have different airflow rates for the same IT load; intake temperature, chip temperatures and server power supply failure. Check the EC temperature graphs to rule out intake temperature as the cause. It is important to look at temperature intake at multiple rack heights. Often racks at the end of the row can see hot air at the intake – this condition would only exist when all the racks in the data center do not have an EC system on them. If all three reasons mentioned as ruled out, please call customer service.

Q: Why did the EC capacity keep increasing when there is no load in the rack and what should I do about this?

A: The EC system continually adjusts to maintain the set operating pressure. With no load in the rack, the EC system is trying to operate with an infinitely small pressure change. We recommend un-plugging the unit until a load is placed in the rack. In this condition, a small amount of cool air will bypass through the EC units that are off.

Q: I made a mistake on the IP set up, how can I get back to the factory setting?

A: Press and hold the reset button located under the Ethernet port until the red LED indicators both light up solid, then release. A small probe will be required to depress the reset button.

Q: I have been getting nuisance alarms for temperature and capacity, how can I change these?

A: The Opengate EC system ships with predefined alarm thresholds. These alarm setting should be changed to meet your site conditions and requirements.

Q: What SNMP versions do the EC systems support?

A: Versions 1 and 2.

Q: I noticed that some of my data logs had gaps of several minutes up to 2 hours, all at the same time one day. What could have caused this?

A: When EC systems are powered down they do not continue to collect data. Any time the power needs to be interrupted for servicing a cabinet, we suggest that the units' logs be downloaded before removing power so as not to lose any data.

Host controller reset to factory default IP address procedure

Power host and wait until you see the 2 red activity LEDs begin to alternate.

Locate the small probe hole below the Ethernet (RJ45) jack.

Using a probe (even a medium size paper clip, straightened) place through the hole to located the soft feel push switch on the circuit board. You should be able to feel a slight click when you have it depressed.

Depress and hold the switch until the activity LEDs both freeze in the on mode, then release the switch. (This usually takes 10-15 seconds, but can vary)

Once the activity LEDs begin to alternate again, the unit has rebooted and you will be able to connect (via crossover cable) using IP address 192.168.123.123, factory default.

Now you can set up all parameters as detailed in the IOM guide.



More Technical Support

Geist
1821 Yolande Ave., Lincoln, NE 68521
800.432.3219 | 402.474.3400 | F: 402.474.4369 |
<http://www.geistglobal.com>
Email:
support@geistglobal.com
Or contact your distributor.

Firmware Updates

Keep your unit updated with the latest firmware releases or sign up for notifications.

<http://www.geistglobal.com/support/cool/firmware>

Geist Americas

800.432.3219 Geist DCIM
geistglobal.com 1.877.449.4150
geistglobal.com

Geist Europe

+44 (0) 1823 275100
geistglobal.com

Geist Asia

China
+86.755.86639505
geistglobal.com

Hong Kong
+852 90361927
geistglobal.com