

Installation and Operation Manual

Containment Cooling®

EC6001C

Issued November 2011

Contact Geist Global for updates

Geistglobal.com

Opengate Data Center Containment Cooling Circuit

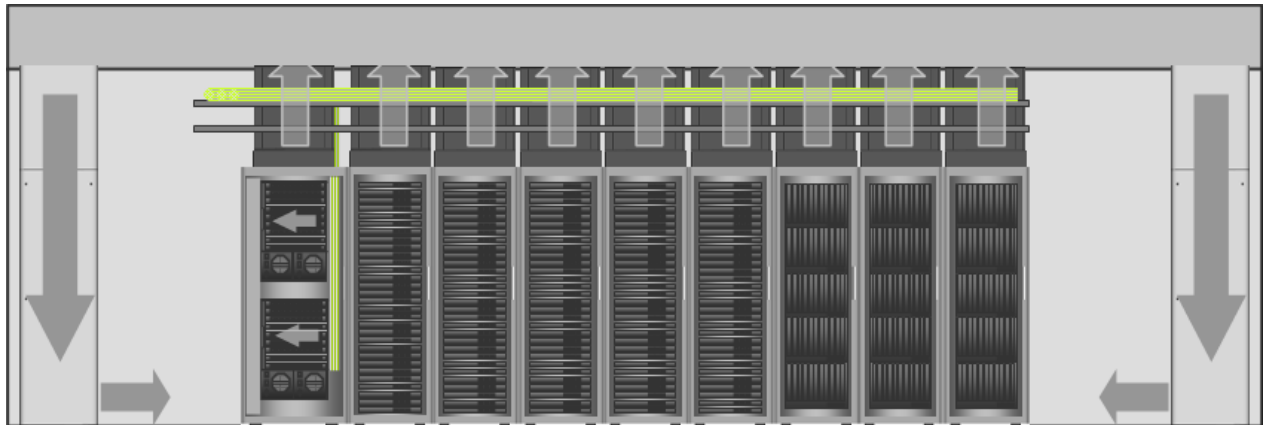

Table of Contents

| | |
|---|----|
| Important Safety Information | 2 |
| System Description & Components | 3 |
| Specifications | 5 |
| Parts List | 5 |
| Tools Needed for Installation | 6 |
| Equipment Cabinet Requirements | 6 |
| Product Installation Procedure | 6 |
| System Reporting | 12 |
| Connecting to the Network and Configuring Notifications | 16 |
| Rack Enclosure & Airflow Inspection Guidelines | 23 |
| Frequent Asked Questions | 28 |



Important Safety Information



- Take care not to drop any foreign objects into the air duct during installation and operation.
- Connect the equipment to a properly grounded three-wire AC outlet.
- The equipment relies on the building installation for protection from over current. A listed 20 amp circuit breaker is required in the building installation.
- Do not attempt to disassemble host controller or fan cartridges; there are no user serviceable components inside.
- All work should be performed by trained and authorized personnel only.
- Keep hands, clothing, and jewelry away from moving parts. Check the equipment for foreign objects before starting the equipment.
- Do not wear jewelry when working near energized components.

System Description

EC Containment Cooling is a fully redundant, modular and scalable pressure controlled system designed to eliminate bypass and maintain proper rack to IT equipment airflow in a heat containment configuration

- Dual input power with auto-sensing logic
- Auto-sensing 0-10, 0-20 kW or 0-30 kW redundant hot-swappable fan cartridges
- Network capability for remote management and alarm notification through web or SNMP
- Local display of status and alarm conditions
- Floating connectors on host controller accept EC10, EC20 or EC30 fan cartridges
- Modular and tool-less quick-swap enclosure
- All cable connections retained or self locking
- Factory pre-set controls; install and connect to power for automatic operation
- Web enabled and full SNMP communication for trending and alarms
- EC Containment Cooling with Unity Cooling Automates the entire data center cooling circuit

Major System Components



EC System

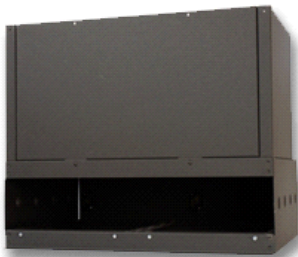

EC Chassis & Duct



EC Host



EC Fan Cartridge

System Top View

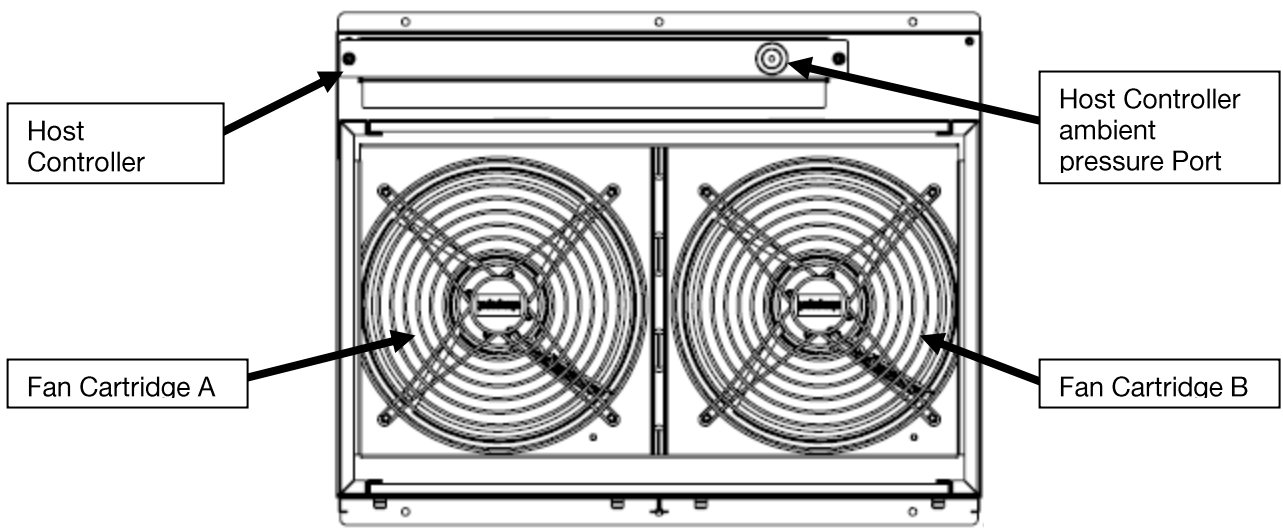

Host Controller

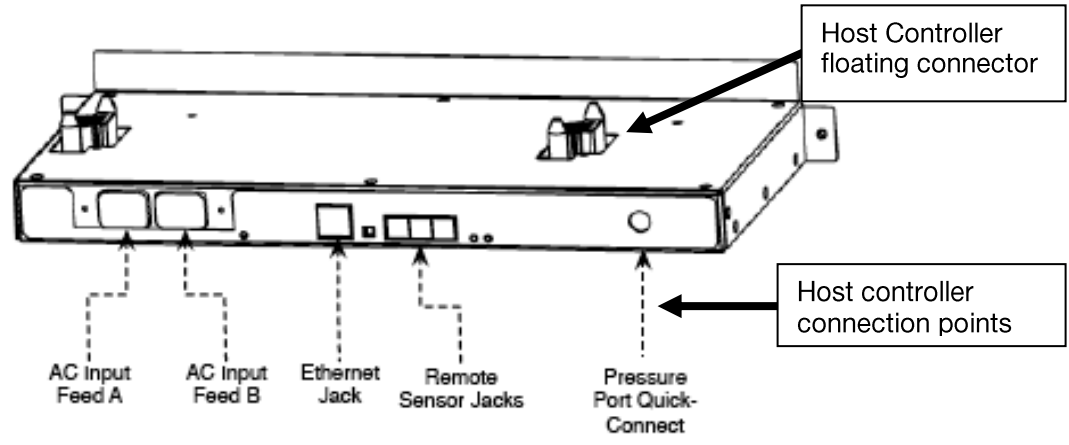

Specifications

| Physical | |
|-------------------------------|---|
| Dimensions | Standard Chassis: 7.53 H x 23.45 W x 18.64 D inches (191.26 H x 595.63 W x 473.46 D mm) |
| Net weight | 44 lbs (20 kg) |
| Shipping weight | 53 lbs (24 kg) |
| Electrical | |
| Input Power | 120-208 Volt, 50-60 Hz, single phase and 208-240 Volt, 50-60 Hz single phase |
| Input Sources | 2 |
| Input Power at 208V/230V | EC10: 130 W @ 80%, 230 W @ 100% / 110 W @ 80%, 210 W @ 100% EC20: 155 W @ 80%, 265 W @ 100% / 140 W @ 80%, 250 W @ 100% EC30: 175 W @ 80%, 310 W @ 100% / 165 W @ 80%, 300 W @ 100% |
| Input Receptacles | IEC-320 C14 |
| Network Settings (default) | |
| IP Address | 192.168.123.123 |
| Subnet Mask | 255.255.255.0 |
| Default Gateway | 192.168.123.1 |
| Environmental | |
| Operating conditions | 3,000 m max elevation; 0-95% non-condensing humidity; 0-60 degrees C |
| Storage conditions | 15,000 m max elevation; 0-95% non-condensing humidity; -20 to 60 degrees C |
| Audible noise at 3 feet (1 m) | < 60 dB |
| Airflow rate | EC10: 1120 CFM max EC20: 2034 CFM max EC30: 2380 CFM max |
| Conformance | |
| Approvals | UL, cUL, CE, C-tick, FCC Class A Part 15 |
| Warranty | 2 year |

Parts List

- 1 EC Chassis
- 2 EC Fan Cartridges
- 1 EC Host
- 4 Interlocking Duct Pieces (ordered separately)
- 1 EC Pressure Sensor Kit
- 1 Hardware Kit - containing fasteners needed for system installation
- Inter-duct Connectors (ordered separately)

Tools Needed for Installation

- #2 Philips head screwdriver
- 3/8 in wrench

Equipment Cabinet Requirements

The EC system can be mounted on any equipment cabinet that meets the following requirements:

- Minimum width – 23.6 inches (600mm)
- Minimum depth – 25.6 inches (650mm)

The EC system utilizes cabinet plenum pressure to control the exhaust fan speed. For proper operation, the equipment enclosure must have a solid rear door, side panels, top panel, bottom panel and front blanking panels. Gaskets around the door, bottom or side panels are not required. Brush strips around cabling are recommended.

Product Installation Procedure

Follow these instructions to install the EC Containment Cooling system.

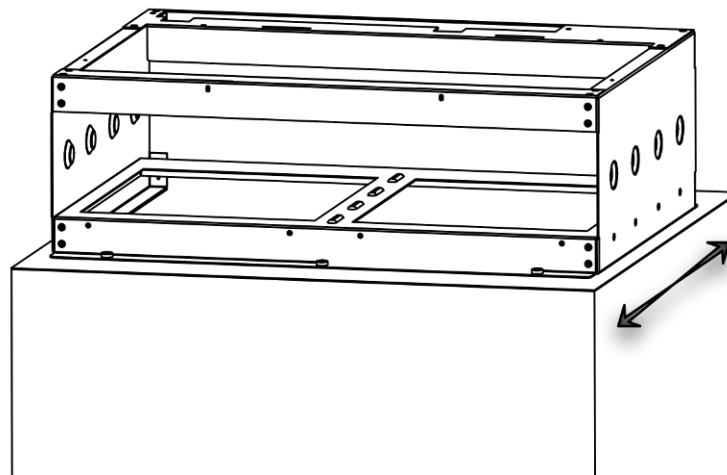

EC Chassis

Positioning the EC System - The EC10 or EC20 system mounts on the top the equipment cabinet as shown. The mounting location is user selectable; however optimal performance is achieved when the EC system is positioned at the rear of the cabinet.

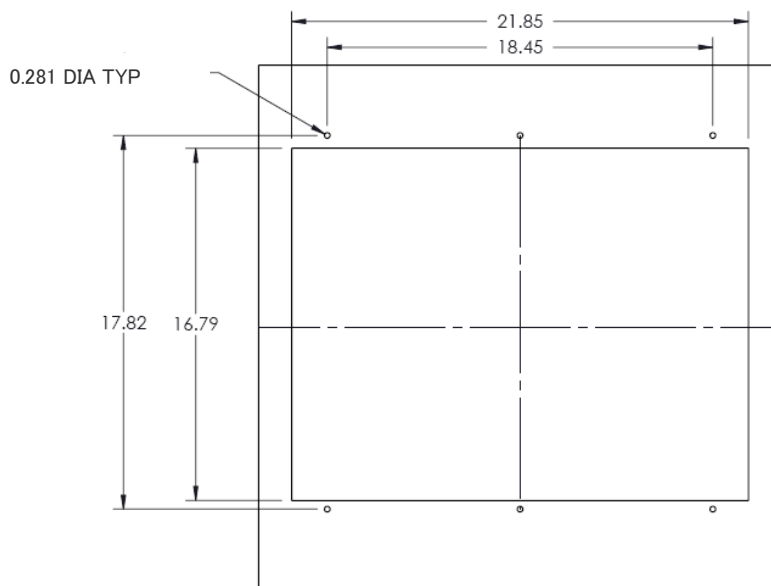

Top Panel Cut Out

Top panel cut out – The top panel of the equipment cabinet will need a pattern cut out of it to allow for the exhaust of hot air. This is shown.

For new installations, the Opengate top panel template can be provided to the cabinet manufacturer such that the cut out is made during the fabrication process and is in place upon receipt of the equipment.

For retrofit installations, replacement top panels with the cut out can be ordered from the cabinet manufacturer or Geist Global.

Mounting the EC chassis on the equipment cabinet

- If the host power and communications module or the fan cartridges are installed, remove them to avoid damage or injury.
- Place the chassis on top of the equipment cabinet with the fan cartridge bays facing the rear door. For shorter duct lengths, the duct can be attached to the chassis before placing the chassis on the rack.
- Align the mounting holes of the chassis with those in the cabinet top panel and attach with the supplied hardware

Exhaust duct assembly – Mounting the exhaust duct to the EC chassis

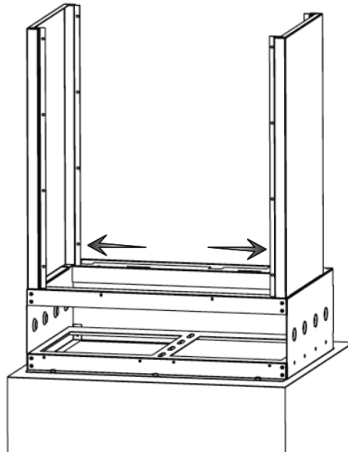

Attaching Exhaust Duct Sides

- Install left and right side panels as shown. Ensure panels snap onto the chassis.

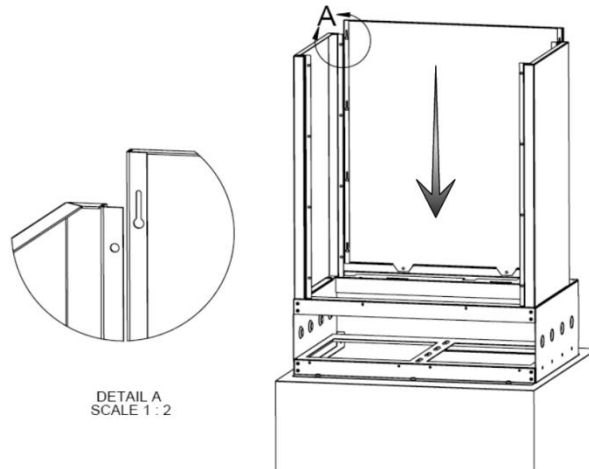

Attaching Exhaust Duct Panels

- Install duct panel by inserting the captive posts into the eyelet slots of both side panels, as shown. Side panel down until tabs are completely fitted into slots and the lower edge is flush with the chassis.
- Secure panel to chassis by installing the 2 mounting screws (#6-32 x 3/8 black Philips head)

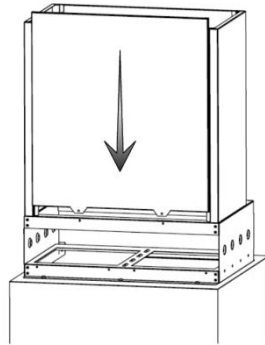

Attaching Exhaust Duct Panel

- Install duct panel by inserting the duct hooks into the slots of both side panels, as shown. Side panel down until tabs are completely fitted into slots and the lower edge is flush with the chassis.
- Secure front panel to chassis by installing the 2 mounting screws (#6-32 x 3/8 black Philips head)

Attach Inter-duct connectors between EC Systems

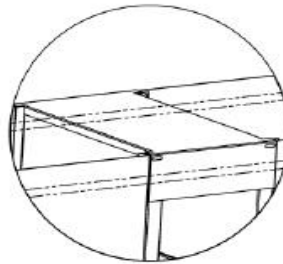

Detail B
Inter-duct connector

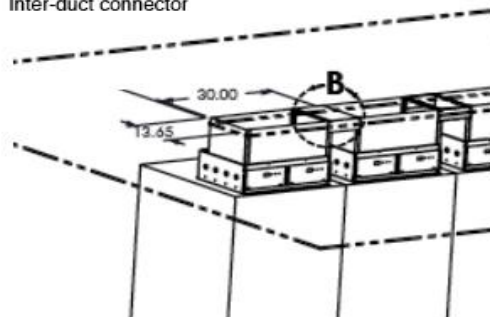

Duct to Ceiling Interface

An inter-duct connector for 750mm/30 inch wide racks is shown. The inter-duct connector for 600mm/24 inch wide racks is considerably shorter in width. A good fit between the heat containment ducts and the ceiling is required to prevent the mixing of supply and exhaust air. Install inter-duct connectors between adjacent ducts, as shown and ensure there is no significant air gap around the perimeter of the ducts.

Host Controller installation

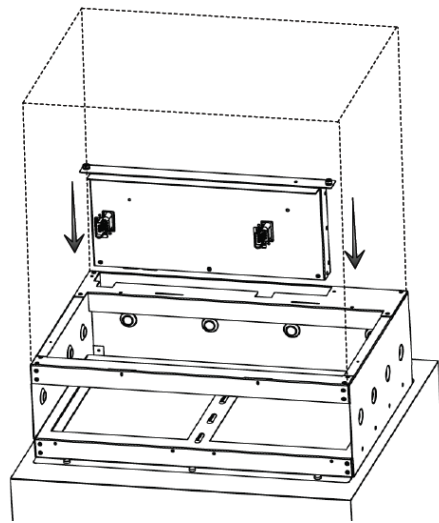

Installing the Host controller

- Insert host power and communications module into EC chassis as shown.
- Secure host power and communications module by tightening the 2 thumbscrews

Fan cartridge installation

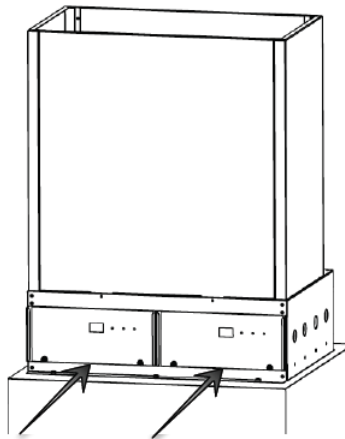

Installing the Fan Cartridges

- Insert fan cartridges into EC chassis as shown.
- Secure fan cartridges by tightening the thumbscrews.

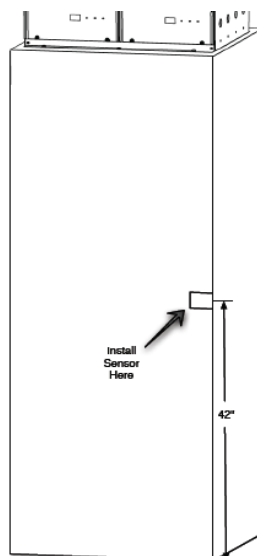

Locating the Pressure Sensor

Sensor hose attachment and installation – The sensor hose is used to communicate the rack plenum pressure to the host module. Mounted on one end of the hose is a quick connect fitting to facilitate ease of installation to the EC Host Controller.

- Locate the end of the sensor hose approximately at the mid-point of the IT load.
- Attach sensor hose to host control module inlet port, as shown.
- Place the sensing end of the hose at the desired location and secure to cabinet with supplied mounting hardware.

Note: Do not remove mechanical baffle from sensor hose as this will affect system performance.

Host Controller Connections – illustrates the EC system connections

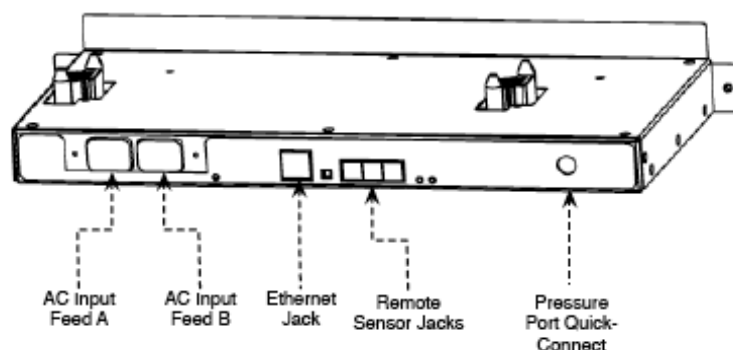

Connecting to the EC Host

Retaining Power Cords on the EC Host

The EC Host includes a power cable retention bracket as shown.

The retention bracket is already installed at the factory for your convenience.

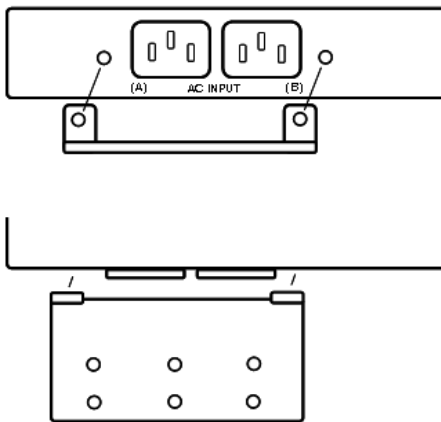

EC Host Power Cable Retention

System Reporting

Front Panel Display

The front panel of each SiteX EC Fan Cartridge has 2 display elements, a numeric display and an LED Panel as shown. Each numeric display illuminates cooling capacity in GREEN, to indicate normal operation, cooling capacity in RED to indicate an alarm condition or temperature alarm in RED FLASHING to indicate an alarm condition. Each LED Panel has 3 LEDs that illuminate GREEN to indicate normal conditions, ORANGE to indicate warning conditions and RED to indicate alarm conditions.

Dual Fan Cartridge Front Panels

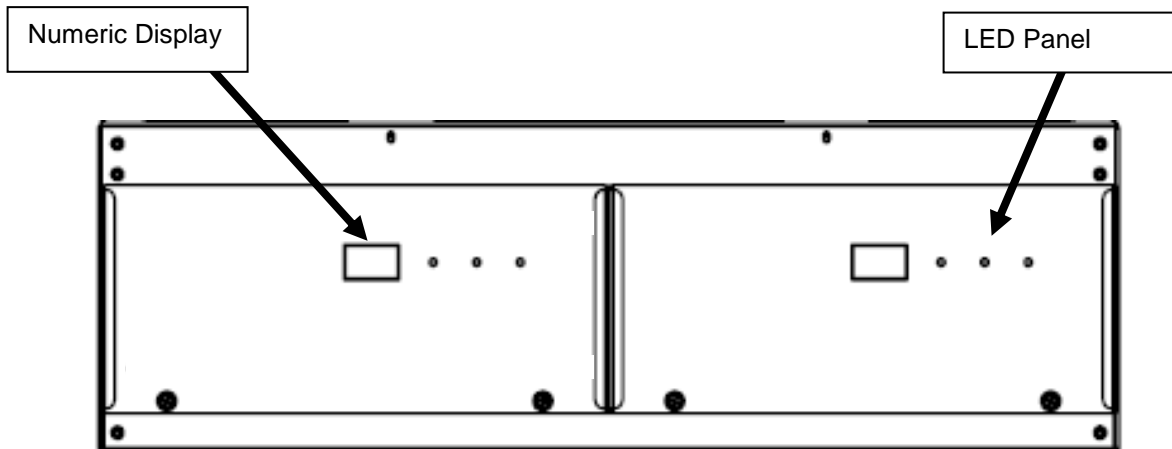

The following table summarizes the fan cartridge front panel display reporting

| Numeric Display | GREEN | RED | FLASHING RED | ALARM ACTION |
|------------------|------------------------------|--------------------------|--------------------------|--|
| Cooling Capacity | Within acceptable parameters | Exceeded alarm condition | N/A | Increase set point Increase fan size Add EC unit to row |
| Temperature | N/A | N/A | Exceeded alarm threshold | Check set points Check rack hot air leak or cool air bypass |

| LED Panel | GREEN | ORANGE | FLASHING RED | ALARM ACTION |
|--------------------|------------------------------|----------------------------|--|--|
| Capacity (cooling) | Within acceptable parameters | Exceeded warning threshold | Exceeded alarm threshold | Increase set point Increase fan size Add EC unit to row |
| Temp ¹ | Within acceptable parameters | Exceeded warning threshold | Exceeded alarm threshold | Check set points Check rack hot air leak or cool air bypass |
| System | System normal | N/A | <ol style="list-style-type: none"> 1. Loss of A/B Power 2. Missing fan 3. Mismatched fan 4. Fan unit failed 5. Fan unit RPM 6. Fan end of life | <ol style="list-style-type: none"> 1. Check power cord 2. Check fan insertion 3. Use same fan 4. Replace fan 5. Replace fan 6. Order spare fan |

(1) Temp LED reports remote temperature, remote humidity or exhaust temperature

Web Interface SiteX View Page

The SiteX View page provides indication of system status using OK in GREEN to green to indicate normal operation, Caution in ORANGE to indicate warning conditions and ALARM in RED to indicate alarm conditions and has two key focal points for information; **SiteX View Summary & Real-time/History Data**

SiteX View Page

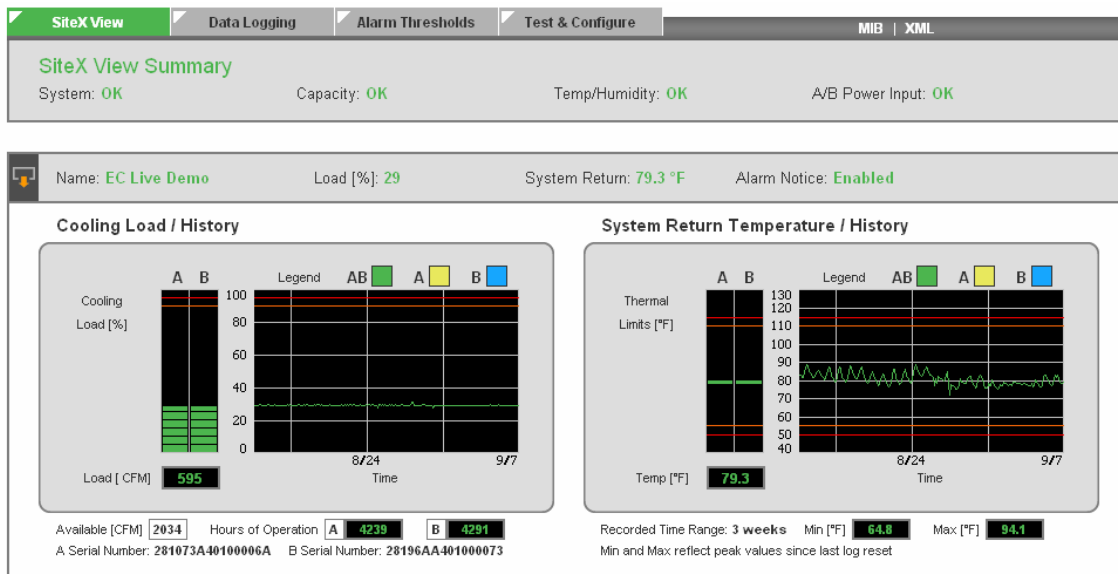

The following table summarizes the SiteX View page reporting

| SiteX View Summary | OK (GREEN) | CAUTION (ORANGE) | ALARM (RED) | ALARM ACTION |
|----------------------------|------------------------------------|----------------------------------|--|--|
| System | System normal | N/A | <ol style="list-style-type: none"> 1. Loss of A/B Power 2. Missing fan 3. Mismatched fan 4. Fan unit failed 5. Fan unit RPM 6. Fan end of life | <ol style="list-style-type: none"> 1. Check power cord 2. Check fan insertion 3. Use same fan 4. Replace fan 5. Replace fan 6. Order spare fan |
| Capacity | Within acceptable parameters | Exceeded warning threshold | Exceeded alarm threshold | Increase set point Increase fan size Add EC unit to row |
| Temp/Humidity ¹ | Within acceptable parameters | Exceeded warning threshold | Exceeded alarm threshold | Check set points Check rack hot air leak or cool air bypass |
| A/B Power Input | Both power feed available | N/A | A Feed or B Feed Only | Check power cord or feed |
| Real-time/History | VALUE (GREEN) | VALUE (ORANGE) | VALUE (RED) | ALARM ACTION |
| Cooling Load (capacity) | Value within acceptable parameters | Value exceeded warning threshold | Value exceeded alarm threshold | Increase set point Increase fan size Add EC unit to row |
| System Return (temp) | Value within acceptable parameters | Value exceeded warning threshold | Value exceeded alarm threshold | Adjust set point Reduce temp by lowering pressure set point |
| Remote Sensor (temp) | Value within acceptable parameters | Value exceeded warning threshold | Value exceeded alarm threshold | Adjust set point Check rack hot air leak or cool air bypass |
| Remote Sensor (humidity) | Value within acceptable parameters | Value exceeded warning threshold | Value exceeded alarm threshold | Adjust set point or cooling system |

(1) Temp LED reports remote temperature, remote humidity or exhaust temperature

Web Interface Data Logging Page

SiteX EC collects historical data for up to 1 month. All system, capacity and environmental data is logged and can be displayed at various time scales from 15 minutes to 1 month.

Data Logging Page

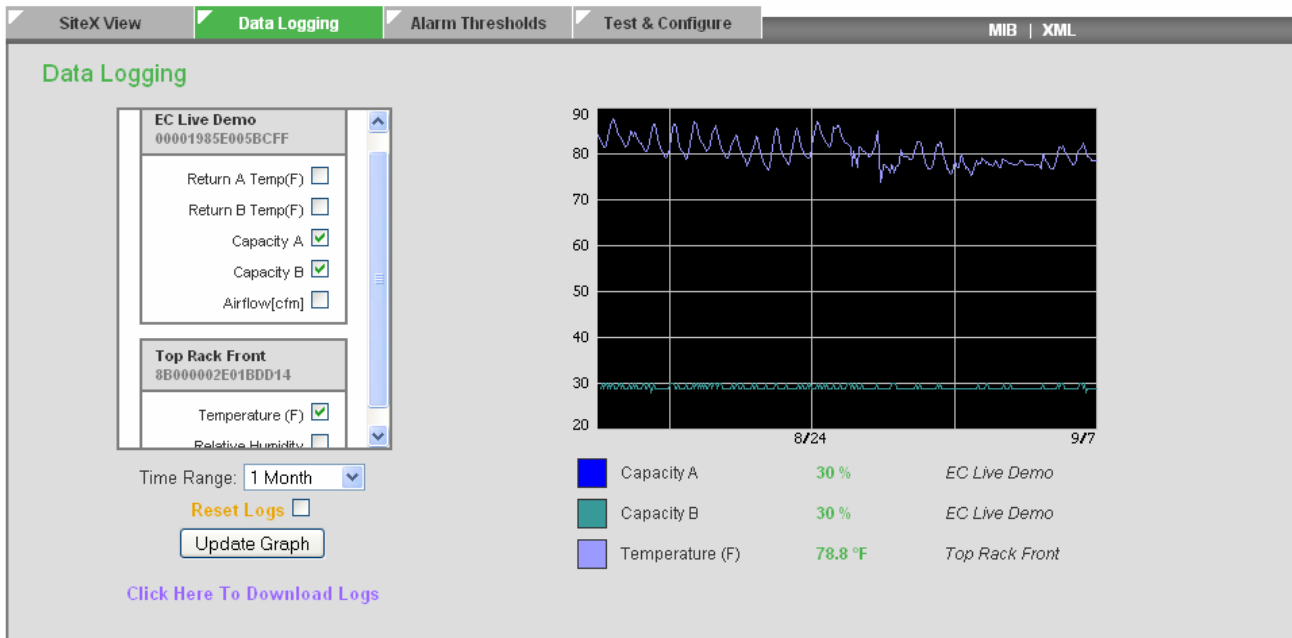

The vertical axis units scale adjusts based on the greatest units for a desired checkbox. To achieve greater visibility, select units with the same ranges before updating graph. Selecting checkboxes for viewing does not affect data logging. All data available is logged and kept for the past 1 month. The horizontal axis date scale adjusts based on the latest available data that data has been collected up to 1 month.

The following table summarizes the Data Logging page;

| Data Logging | Steps |
|---------------|---|
| Viewing Data | Check boxes for the parameters desired and then select Time Range and then select Update Graph . |
| Download Logs | Select Click Here to Download Logs and save CSV file to a desire location for viewing later |
| Reset Logs | Select Reset Logs and then select Update Graph . This action will clear all logged data that was available for download and will clear all data from the visible graph. |

Connecting to the Network and Configuring Notifications

Default network settings - The Ethernet port will come from Geist Global programmed with the following default settings:

IP Address: 192.168.123.123

Subnet Mask: 255.255.255.0

Default Gateway: 192.168.123.1

- Install a CAT5 Ethernet cable between the EC Host and the computer being used for device configuration. If connecting directly to the EC and not going through a hub, switch or router, a crossover cable will be required.
- To change the default IP configuration, navigate to the 'Test & Configure' page and expand as shown.

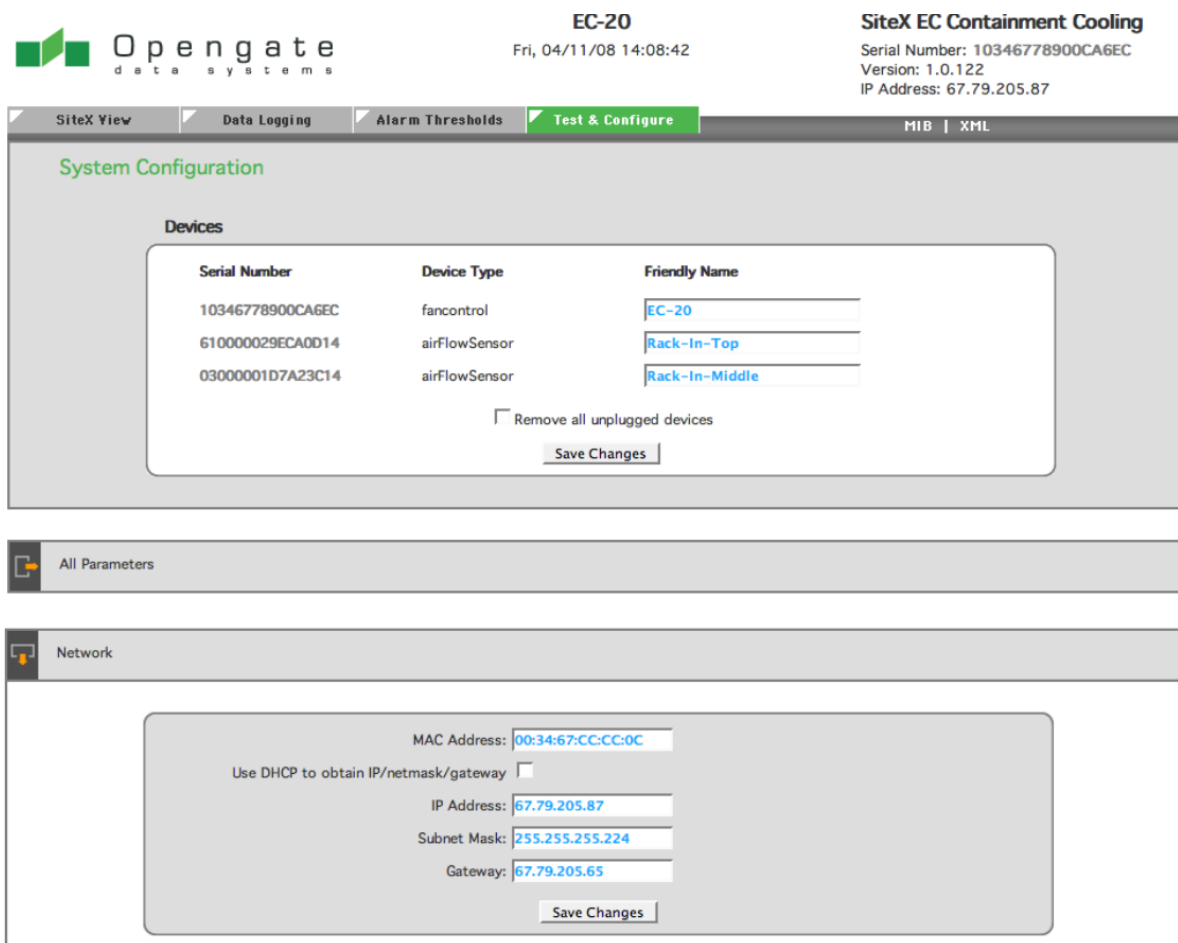

The screenshot displays the 'Test & Configure' web page for an EC-20 device. The page header includes the OpenGate logo, the device name 'EC-20', the date and time 'Fri, 04/11/08 14:08:42', and the device type 'SiteX EC Containment Cooling' with its serial number, version, and IP address. The main content area is divided into two sections: 'System Configuration' and 'Network'.

System Configuration: This section contains a table of devices with the following columns: Serial Number, Device Type, and Friendly Name.

| Serial Number | Device Type | Friendly Name |
|------------------|---------------|----------------|
| 10346778900CA6EC | fancontrol | EC-20 |
| 610000029ECA0D14 | airFlowSensor | Rack-In-Top |
| 03000001D7A23C14 | airFlowSensor | Rack-In-Middle |

Below the table, there is a checkbox labeled 'Remove all unplugged devices' and a 'Save Changes' button.

Network: This section contains fields for network configuration:

- MAC Address: 00:34:67:CC:CC:0C
- Use DHCP to obtain IP/netmask/gateway:
- IP Address: 67.79.205.87
- Subnet Mask: 255.255.255.224
- Gateway: 67.79.205.65

A 'Save Changes' button is located at the bottom of the network configuration section.

Test & Configure Web Page

- Enter the desired IP Address, Subnet Mask and Default Gateway information.
- Select 'Save Changes' for the modifications to be accepted and stored in non-volatile memory of the EC Host.
- If the network is running DHCP the EC can have the configuration settings automatically assigned. To enable this feature, select the 'Use DHCP to obtain IP/netmask/gateway' checkbox and save changes.

Note: Recommended practice is to manually program the SiteX EC IP address and 'friendly name' with the physical location or unique identifier during initial installation. Automatic assignment of the IP address via DHCP does not facilitate this process.

Configuring the email and SNMP trap recipient – To receive alarm notifications through email and/or SNMP trap event, navigate to the Test & Configuration web page and expand the E-mail section as shown.

E-mail

SMTP Server:

64.49.254.24

SMTP Port:

"From" E-mail Address:

To E-mail Address 1:

To E-mail Address 2:

To E-mail Address 3:

To E-mail Address 4:

To E-mail Address 5:

POP3 Server:

POP3 Port:

Username:

Password:

Configuring Email

To configure email notifications through SMTP enter the IP address of the server hosting the email service into the 'SMTP Server' field (in numeric form). The IP address can be discovered by sending a ping to the email server (e.g. ping mail.geistglobal.com).

- Enter a unique identifier into the 'From E-mail Address' field.
- Identify the individual(s) to receive the email notification by entering his or her address into the 'To E-mail Address' field. Enter only one address per field.

Some email servers require a POP3 connection to be established in order to accept email via SMTP. The last three fields are used for this purpose. Normally, the POP3 IP address will be the same as the SMTP Server IP address.

As shown in the next diagram, configure trap directed notification over SNMP, enter the IP address of the SNMP manager into the 'Trap IP Address' field.

| SNMP | Trap 1: | Trap 2: |
|--|---------|---------|
| <p>Read Community: <input type="text" value="public"/></p> <p>Listen port for GET: <input type="text" value="161"/></p> <p>Trap Community: <input type="text" value="private"/></p> <p>Trap IP Address:Port 1: <input type="text"/></p> <p>Trap IP Address:Port 2: <input type="text"/></p> <p style="text-align: center;"><input type="button" value="Save Changes"/></p> | | |

Configuring SNMP

Default Alarm Threshold Settings

SiteX EC is programmed and shipped from the factory with default alarm settings. Alarm threshold values and units can be changed as described in a later section. Following are the default alarm settings:

System Threshold Settings on the Alarm Thresholds Page

System Threshold Settings
Alarm Notice: Enabled

| Source | Type | Threshold | E-mail | Traps |
|----------------------------|--------------|-----------|---|---|
| Capacity | High Alarm | 95 | <input checked="" type="checkbox"/> <input type="checkbox"/> <input type="checkbox"/> <input type="checkbox"/> <input type="checkbox"/> | <input type="checkbox"/> <input type="checkbox"/> |
| | High Warning | 90 | <input type="checkbox"/> <input type="checkbox"/> <input type="checkbox"/> <input type="checkbox"/> <input type="checkbox"/> | <input type="checkbox"/> <input type="checkbox"/> |
| Fan End of Service Warning | High Alarm | 40000 | <input type="checkbox"/> <input type="checkbox"/> <input type="checkbox"/> <input type="checkbox"/> <input type="checkbox"/> | <input type="checkbox"/> <input type="checkbox"/> |
| Return Temp(F) | High Alarm | 115 | <input type="checkbox"/> <input type="checkbox"/> <input type="checkbox"/> <input type="checkbox"/> <input type="checkbox"/> | <input type="checkbox"/> <input type="checkbox"/> |
| | High Warning | 110 | <input type="checkbox"/> <input type="checkbox"/> <input type="checkbox"/> <input type="checkbox"/> <input type="checkbox"/> | <input type="checkbox"/> <input type="checkbox"/> |
| | Low Warning | 55 | <input type="checkbox"/> <input type="checkbox"/> <input type="checkbox"/> <input type="checkbox"/> <input type="checkbox"/> | <input type="checkbox"/> <input type="checkbox"/> |
| | Low Alarm | 50 | <input type="checkbox"/> <input type="checkbox"/> <input type="checkbox"/> <input type="checkbox"/> <input type="checkbox"/> | <input type="checkbox"/> <input type="checkbox"/> |

The following table summarizes the System Thresholds Default Settings;

| System Threshold Setting | High Alarm | High Warning | Low Warning | Low Alarm |
|----------------------------|---|--------------|-------------|-----------|
| Capacity (%) | 95 | 90 | N/A | N/A |
| Fan End of Service Warning | Fan dependant and programmed at the factory. Fan cartridges retain their hours of operation even when not powered | | | |
| Return Temperature (°F) | 115 | 110 | 55 | 50 |

Return Temp thresholds are widely set to prevent nuisance alarms. After facility operational knowledge, settings can be narrowed to provide valuable information about recirculation of hot air through IT equipment or bypass cooling through IT rack.

Remote Sensor Thresholds Settings on the Alarm Thresholds Page

Remote Sensor: **Top Rack Front**
Alarm Notice: **Enabled**

Sensor ID: 8B000002E01BDD14

| Source | Type | Threshold | E-mail | Traps |
|-------------------|--------------|--|---|---|
| Temperature (F) | High Alarm | <input style="width: 40px;" type="text" value="90"/> | <input checked="" type="checkbox"/> <input type="checkbox"/> <input type="checkbox"/> <input type="checkbox"/> <input type="checkbox"/> | <input type="checkbox"/> <input type="checkbox"/> |
| | High Warning | <input style="width: 40px;" type="text" value="80"/> | <input type="checkbox"/> <input type="checkbox"/> <input type="checkbox"/> <input type="checkbox"/> <input type="checkbox"/> | <input type="checkbox"/> <input type="checkbox"/> |
| | Low Warning | <input style="width: 40px;" type="text" value="64"/> | <input type="checkbox"/> <input type="checkbox"/> <input type="checkbox"/> <input type="checkbox"/> <input type="checkbox"/> | <input type="checkbox"/> <input type="checkbox"/> |
| | Low Alarm | <input style="width: 40px;" type="text" value="58"/> | <input type="checkbox"/> <input type="checkbox"/> <input type="checkbox"/> <input type="checkbox"/> <input type="checkbox"/> | <input type="checkbox"/> <input type="checkbox"/> |
| Relative Humidity | High Alarm | <input style="width: 40px;" type="text" value="80"/> | <input type="checkbox"/> <input type="checkbox"/> <input type="checkbox"/> <input type="checkbox"/> <input type="checkbox"/> | <input type="checkbox"/> <input type="checkbox"/> |
| | High Warning | <input style="width: 40px;" type="text" value="60"/> | <input type="checkbox"/> <input type="checkbox"/> <input type="checkbox"/> <input type="checkbox"/> <input type="checkbox"/> | <input type="checkbox"/> <input type="checkbox"/> |
| | Low Warning | <input style="width: 40px;" type="text" value="35"/> | <input type="checkbox"/> <input type="checkbox"/> <input type="checkbox"/> <input type="checkbox"/> <input type="checkbox"/> | <input type="checkbox"/> <input type="checkbox"/> |
| | Low Alarm | <input style="width: 40px;" type="text" value="20"/> | <input type="checkbox"/> <input type="checkbox"/> <input type="checkbox"/> <input type="checkbox"/> <input type="checkbox"/> | <input type="checkbox"/> <input type="checkbox"/> |

The following table summarizes the System Thresholds Default Settings;

| Remote Sensor Alarm Threshold | High Alarm | High Warning | Low Warning | Low Alarm |
|-------------------------------|------------|--------------|-------------|-----------|
| Remote Sensor Temp (°F) | 90 | 80 | 64 | 58 |
| Remote Sensor Humidity (Rh) | 80 | 60 | 35 | 20 |

Remote Sensor Temperature and **Humidity** high/low alarms are set to the ASHRAE Allowable environment guidelines and high/low warnings are set to the ASHRAE Recommended environment guidelines for IT equipment intake air.

Adjusting System Settings & Enabling Alarms

Notifications in the form of email and SNMP trap events are delivered when an alarm thresholds has been exceeded. Select the desired email or trap notification by checking one or more the boxes to the right of the alarm type and **Save Changes**.

Alarm Threshold Page

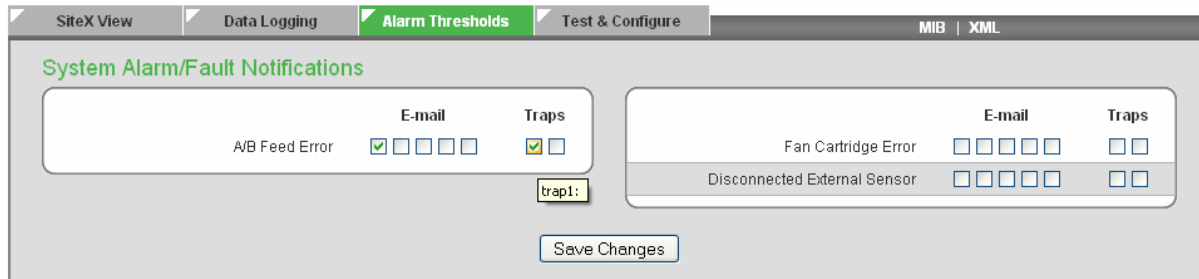

To change threshold values, double click in the value window to highlight the existing value. Type in the new value and then select **Save Changes**.

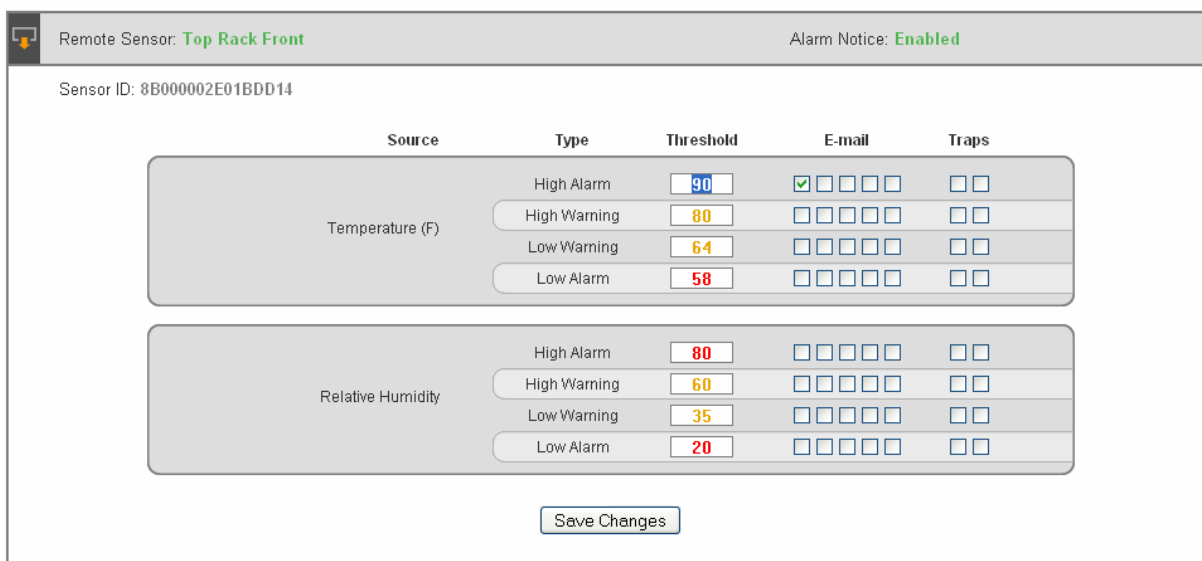

| Source | Type | Threshold | E-mail | Traps |
|-------------------|--------------|-----------|-------------------------------------|--------------------------|
| Temperature (F) | High Alarm | 90 | <input checked="" type="checkbox"/> | <input type="checkbox"/> |
| | High Warning | 80 | <input type="checkbox"/> | <input type="checkbox"/> |
| | Low Warning | 64 | <input type="checkbox"/> | <input type="checkbox"/> |
| | Low Alarm | 58 | <input type="checkbox"/> | <input type="checkbox"/> |
| Relative Humidity | High Alarm | 80 | <input type="checkbox"/> | <input type="checkbox"/> |
| | High Warning | 60 | <input type="checkbox"/> | <input type="checkbox"/> |
| | Low Warning | 35 | <input type="checkbox"/> | <input type="checkbox"/> |
| | Low Alarm | 20 | <input type="checkbox"/> | <input type="checkbox"/> |

Test & Configure Page

Modify **Friendly Names** to each **Device Type** (system and up to 3 remote sensors) and then select **Save Changes**.

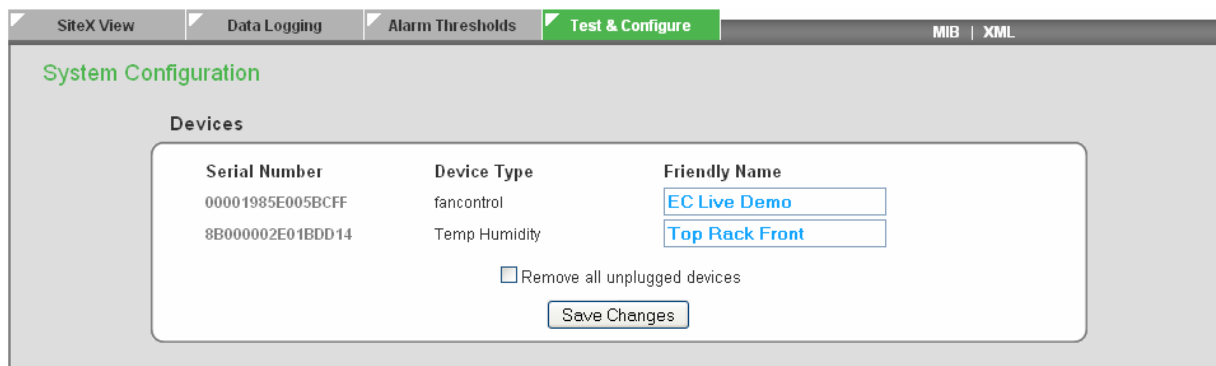

| Serial Number | Device Type | Friendly Name |
|------------------|---------------|----------------|
| 00001985E005BCFF | fancontrol | EC Live Demo |
| 8B000002E01BDD14 | Temp Humidity | Top Rack Front |

System Clock - Test & Configure Page

Resetting **System Clock** and then select **Save Changes**. Setting clock is necessary for data logging capability. System clock settings are lost after a few weeks of the Host Controller not being powered.

System Clock, set to GMT

Set Clock method: NTP Server

GMT to local, (+/-)hh:mm -05:00

| | | | | | |
|---|---|---|---|---|---|
| Month | Day | Year | Hour | Minute | Second |
| 09 | 07 | 09 | 17 | 44 | 52 |
| | | <small>(yy)</small> | <small>(0-23)</small> | <small>(0-59)</small> | <small>(0-59)</small> |

NTP primary server 192.43.244.18
192.43.244.18

NTP secondary server 129.6.15.28
129.6.15.28

Sync to NTP server period (seconds) 1800

Save Changes

E-mail - Test & Configure Page

Re-assigning **E-mail** with each email address corresponding to each checkbox in the **Alarm Thresholds** page and then select **Save Changes**.

E-mail
SMTP:
POP3:
Authentication: Disabled

SMTP Server:

SMTP Port: 25

Leaving the POP3 Server blank with the Username/Password filled in and using SMTP Port 465 enables ESMTP/SSL.

"From" E-mail Address: dev@opengatedata.

To E-mail Address 1:

To E-mail Address 2:

To E-mail Address 3:

To E-mail Address 4:

To E-mail Address 5:

POP3 Server:

Leaving the POP3 Server blank with the Username/Password filled in enables ESMTP/TLS. No POP3 Server and no Username/Password enables no authentication.

POP3 Port: 110

Username:

Password:

Save Changes

SNMP - Test & Configure Page

Re-assigning **SNMP** traps with each trap corresponding to each checkbox in the **Alarm Thresholds** page and then select **Save Changes**.

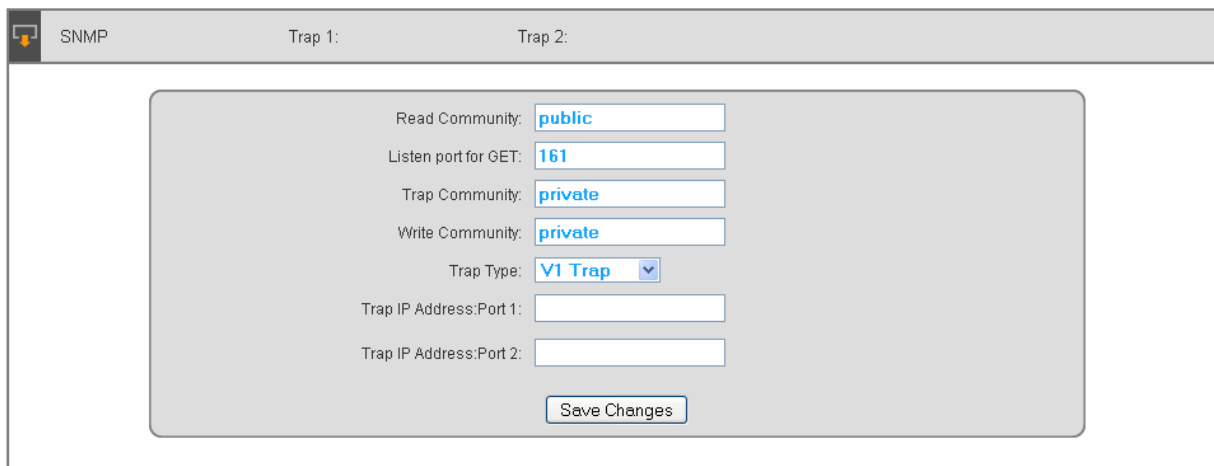

Test E-mail or SNMP - Test & Configure Page

After changing **E-mail** or **SNMP** trap address information select **Send** to test notification.

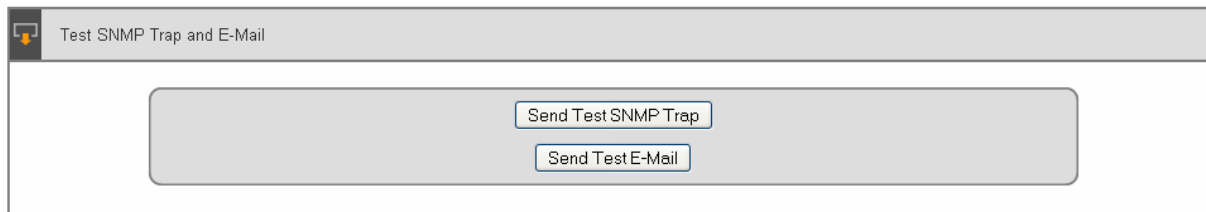

Units - Test & Configure Page

Change **Units** to Imperial (Fahrenheit and CFM), Metric (Celsius and MCH) or Imperial/Metric (Celsius and CFM) and then select **Save Changes**.

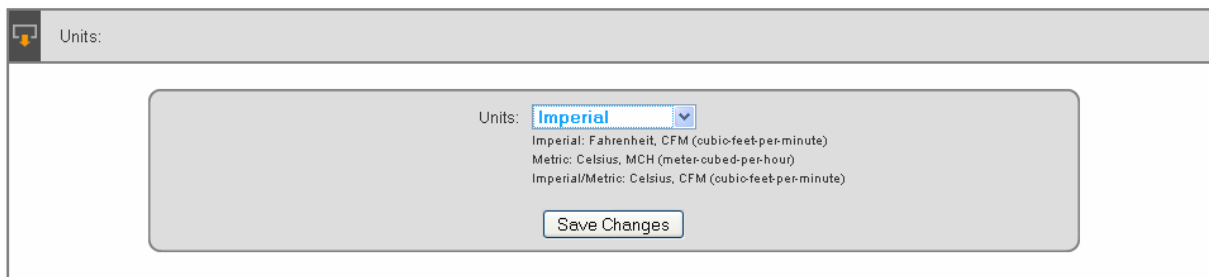

Fan Fail Test - Test & Configure Page

To determine the operational or environment effects of a single fan failure, select **FAN A** or **FAN B**, enter a **Test Time** in seconds and select **Run Test**. Operating and environment conditions can be observed remotely from the SiteX View or Data Logging page.

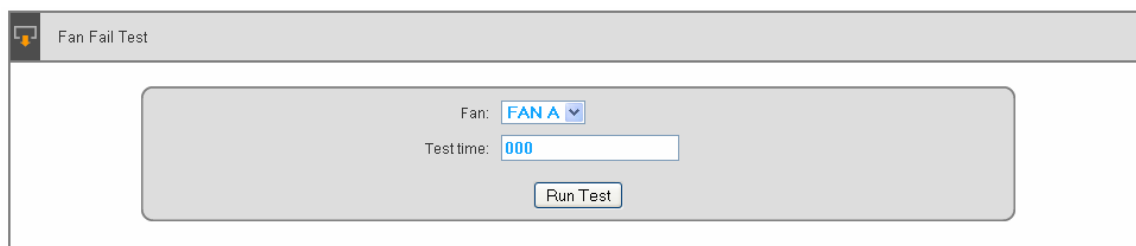

Fan Fail Test

Fan: **FAN A**

Test time: **000**

Run Test

Rack Enclosure & Airflow Inspection Guidelines

Rack Top Panel

Cable entry through the rack top panel should be made through brush strips to prevent cold air bypass into the rack, returning to the cooling units. Openings near the top of the rack will cause the EC units to run at a higher capacity that is required.

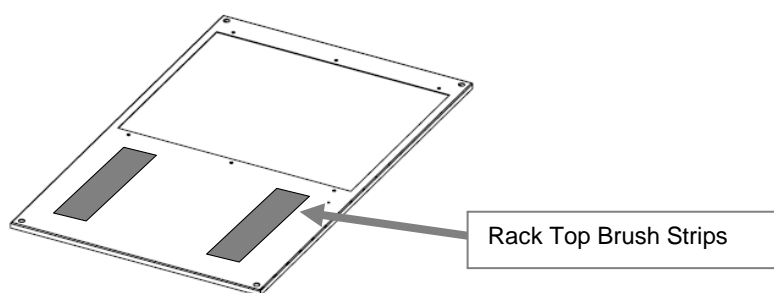

Rack Side Panels and Rear Door

Racks must be deployed with solid side panels and solid rear doors to contain heat and allow pressure control per an individual enclosure. Side panels should cover at least 75% of the rack side area. Sealing strips are not required for rear door frame perimeter.

Rack Front Mounting Rails & Blanking Panels

Racks must be deployed with front rails and blanking panels that do not allow hot air to leak out at the front of the rack. Inspect rack for obvious leakage paths that are larger than 0.25 inches (6mm).

Checking Pressure Sensor Location

The pressure sensor is used to communicate the rack plenum pressure to the host controller module. The pressure sensor should be located at approximately the mid-point of the cabinet. Front-to-rear sensor position with respect to the rear of the IT equipment will not affect operation. Do not mount the pressure sensor at a U height position where there is no IT equipment mounted. This will produce a slightly lower pressure reading and result in a slightly lower capacity than required. Do not mount the pressure sensor at a U height position where there may be a few servers that are excessively deeper than the other servers in the same rack. This will produce a slightly higher pressure reading and result in a slightly higher capacity than required.

EC Capacity Meter Guideline

It is typically normal to have EC systems indicate different capacity for racks with exactly the same IT load.

It is quite common to have two racks with the same IT power load running at different flow rates – hence a different EC capacity. There are multiple reasons for varying airflow rates for the same IT power load. They are; IT equipment intake temperature variation, IT equipment chip temperature variation, IT equipment single power supply failure or excessive rack openings (such as blank panels missing) allowing cool air bypass.

Check the EC intake temperature graphs to rule out intake temperature as the cause. It is important to look at intake temperature at multiple rack heights. IT equipment at the top of the rack could be running higher airflow rates because of a higher temperature there. Often racks at the end of the row can see hot air at the intake – a condition that would only exist if a substantial number of the racks in the data center did not have an EC system installed.

For the same power load, if the intake temperature between two racks is the same but the exhaust temperature is different, it suggests the IT equipment in the rack has a different airflow rate versus the other or there is bypass cooling going through an open U space or through openings at the top panel of the rack, reducing the EC exhaust temperature. Higher IT equipment flow rates for the same power load or bypass cooling will cause the EC capacity to run higher.

If all reasons described here are ruled out, please call customer service.

If the EC capacity keeps increasing when there is no load in the rack you will need to unplug the EC unit or change its pressure set point to a higher value.

The EC system continually adjusts to maintain the set operating pressure. With no load in the rack, the EC system is trying to operate with an infinitely small pressure change. We recommend un-plugging the unit until a load is placed in the rack. In this condition, a small amount of cool air will bypass through the EC units that are off. Also, changing the fan operation pressure set point to a 0.008 positive value will reduce the fan speed.

Cool Supply Air Inspection Guideline

Cool supply air volume that is delivered can be compared to how much cool supply air is being consumed by the IT equipment. This function can be automated with an SNMP manager by collecting all Opengate EC CFM data in the environment and aggregating the volume of cool air being consumed.

Two examples of cool supply volume versus IT demand. The second Example is provided from the ASHRAE High Density Data Centers Best Practices and Case Studies book.

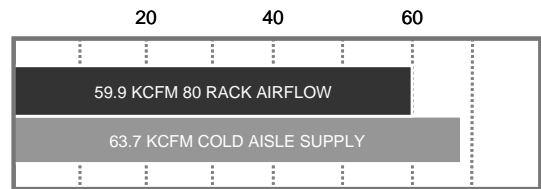
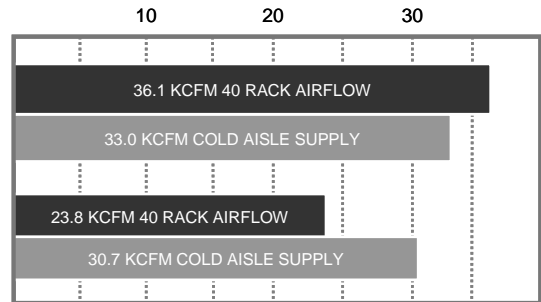
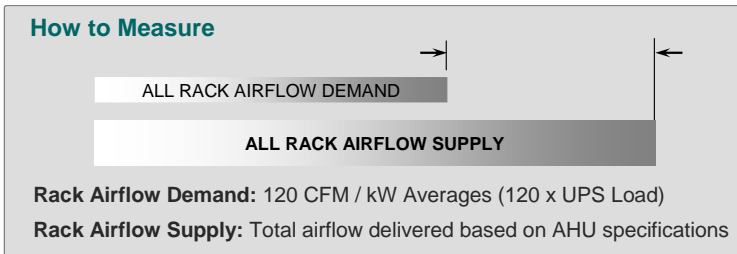

Total airflow consumption is compared to the total airflow supplied by looking at the AHU output volume. When AHU are speed controlled, airflow is directly proportional to fan speed.

Fan power is to the third power of airflow output. For example; when a fan is operating at 75% airflow, it is only consuming about 50% of the total power when at full airflow output. At 50% airflow output from the AHU fans, only one sixth the power is consumed.

Impact of over-supply and data center loading on AHU fan power with adjustable flow rates

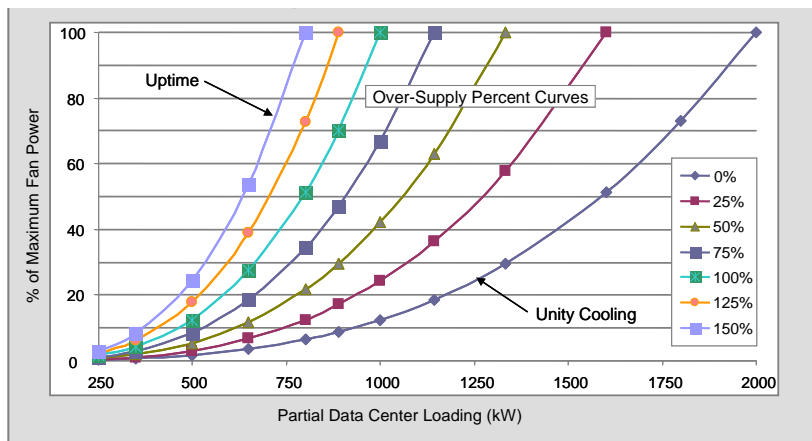

Cool Supply Air Temperature

A reliable rack intake temperature at every point in the data center is possible even with supply air temperatures elevated toward the upper ASHRAE limits. ASHRAE defines the range for recommended temperatures at 64 to 80 Deg F or 18 to 27 Degrees Celsius.

Higher rack inlet temperatures to 90 Deg F or 32 Deg Celsius are allowed for short durations. As confidence in the industry that a raised supply air temperature can be safely maintained, the areas to check for contamination of cool supply with waste heat are as follows;

- Baseline supply air temperature at release points such as vertical overhead vents or perforated tiles in a raised floor delivery system
- Measure rack intake temperature 1M from the floor at the middle rack and end rack of each aisle.
- When experiencing elevated temperatures, greater than 2-3 degrees Celsius above the supply at any rack intake, check temperature right at the rack front mounting rails. If hot air leakage is present 1M from the floor at the rack mounting rails, this may indicate a rack is at an elevated pressure, causing hot air leakage.

Cool Supply Air Temperature to IT Equipment

The Opengate EC system reports and alarms on remote temperature and humidity sensors. This temperature can be tracked over time and alarm thresholds can be adjusted based on prior experience. For standard front-to-back cooled devices, a remote temperature/humidity sensor can be placed at the end racks in an aisle and at the center rack in the aisle, 1M from the floor. For IT equipment with side airflow intake, a remote sensor can be placed right at the intake grill of the IT device.

To encourage cool air to enter along the side of the side airflow intake equipment, set the EC system rack operating pressure to a negative value and monitor intake temperature for validation. ***A setting of -0.008 is a good starting point to encourage cool air entry at side intakes.***

Hot Return Air Inspection Guideline

Hot air leakage from the IT rack to the intake of the IT equipment will limit your ability to increase rack density, raise supply air temperature, control the environment and improve cooling efficiency. Examples of cool air bypass and hot air leakage associated with rack heat containment are depicted in the two figures below. *The left figure* illustrates cool air bypass due to a negative rack pressure. *The right figure* demonstrates hot air leakage out of the IT rack caused by high pressure in the lower and middle regions inside the rack. Hot air leakage will elevate IT intake air temperatures. Rack pressure in passive rack heat containment is highly dependent on IT equipment airflow volume and rack air leakage passages.

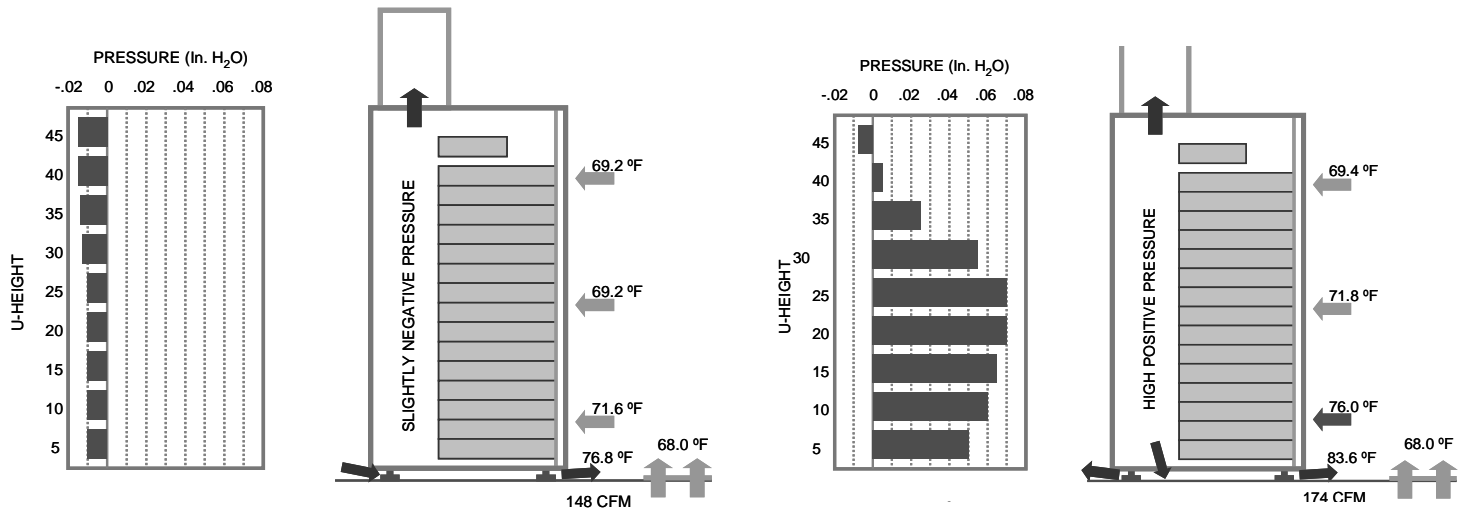

The Opengate EC system reports and alarms on the systems return temperature. This temperature can be averaged for all racks and compared to the AHU return temperature. An AHU with a much lower temperature than the EC system return temperature indicates cool air is bypassing the IT equipment and returning to the AHU unused.

Achieving Maximum Energy Efficiency for Cooling Circuit

A CRAC/H unit deployed in a system allowing a higher supply and return temperature will operate at greater efficiency. Data supplied by a CRAC/H manufacturer demonstrates this cooling capacity increase. The top line is fairly close to a conventionally cooled data center with return temperature controls. With supply air conditions well outside of the ASHRAE Class 1 standard, the sensible cooling of 107 kW is quite a bit lower than the total cooling of 128 kW. The CRAC is also capable of increased capacity as the return air temp is elevated. With the return dry bulb air at 100 °F, the CRAC capacity almost doubles.

45 °F entering chilled water temperature with control valve full open

| Return Dry Bulb (°F) | % Rh | Leaving Fluid Temp (°F) | Total Cooling (kW) | Sensible Cooling (kW) | Sensible Ratio (SHR) | Supply Dry Bulb (°F) |
|----------------------|------|-------------------------|--------------------|-----------------------|----------------------|----------------------|
| 72 (22 C) | 50.0 | 58.5 (15 C) | 128 | 107 | 83% | 51.1 (11 C) |
| 80 (27 C) | 38.3 | 62.0 (17 C) | 164 | 144 | 88% | 51.4 (11 C) |
| 90 (32 C) | 27.8 | 66.5 (19 C) | 210 | 188 | 90% | 52.1 (11 C) |
| 100 (38 C) | 20.4 | 71.0 (22 C) | 255 | 228 | 89% | 53.2 (12 C) |

Data demonstrates maintaining a 68 °F supply dry bulb to increase total cooling and improve the sensible heat ratio (SHR) to allow even greater sensible cooling. Data indicates that the CRAC requires a lower cooling water flow rate and this performance indicates it might be most efficient to dial back some cooling capacity

and let the chillers run at their most efficient operating parameters. Greater temperature differential from chilled water and return air improves coil performance.

45 °F entering chilled water temperature with control valve throttled

| Return Dry Bulb (°F) | % Rh | Leaving Water (°F) | Total Cooling (kW) | Sensible Cooling (kW) | Sensible Ratio (SHR) | Supply Dry Bulb (°F) |
|----------------------|------|--------------------|--------------------|-----------------------|----------------------|----------------------|
| 80 (27 C) | 38.3 | 76.0 (24 C) | 204 | 192 | 94% | 68.2 (20 C) |
| 90 (32 C) | 27.8 | 85.2 (29 C) | 371 | 355 | 96% | 68.3 (20 C) |
| 100 (38 C) | 20.4 | 93.1 (34 C) | 545 | 516 | 95% | 68.1 (20 C) |

Manufacturer’s data demonstrate that chillers run more efficiently and give additional capacity if the chilled water temperature is raised. By raising the entering chilled water temperature from 45 to 50 °F a R134-A high-pressure chiller realizes a 9% capacity increase and a 6% energy savings and a R123 low pressure VFD chiller realizes a 17% capacity increase and a 12% energy savings.

Increasing chilled water temperature will also provide increased hours for available water-side economizer operation, to the point where it becomes economically feasible even in warmer climates. Raising the supply air temperature to 70 °F would require approximately 55 °F (13 C) chiller condenser water. In comparison, a 59 °F (15 C) supply air temperature would require approximately a 45 °F (7 C) condenser water temperature. With a 5 °F approach temperature, water-side economizers could be utilized at outdoor air temperatures up to 50 °F (10 C) for a 70 °F (21 C) supply versus outdoor air temperatures up to 40 °F (4 C) if supply air is left at 59 °F (15 C).

Executing on cooling distribution of the entire cooling circuit, which allows supply air temperatures to safely approach the ASHRAE high end limit, will improve CRAC/H capacity, chiller plant efficiency and maximizes the hours of economizer operation.

Frequent Asked Questions

General & Physical Environment Questions

Q: Where do I mount my pressure sensor?

A: The pressure sensor placement is at the rear of the rack located midway top to bottom of the IT equipment stack. For example; with IT equipment stacked to 30U from the bottom, the sensor height would be between 12-18U for accurate capacity operation. The sensor does not have to be directly behind the IT equipment and can be placed off to the side near the cabling or power strips if desired.

Q: What duct length do I need for a 12 foot height from the floor to the drop ceiling?

A: The duct length is calculated by subtracting the rack height and EC Chassis height from the 12 foot space then add 1.5 inches which allows the duct to pass through the drop ceiling by this amount. We have two EC

Chassis heights; the standard is 7.5 inches tall and the EC Tall Chassis is 11.5 inches. *Example; 144 inches (12 foot space) – 84 inches (rack) – 7.5 inches + 1.5 inches = 54 inch duct*

Q: What is the longest duct Geist Global makes and what if I need a longer one?

A: The longest duct we suggest is 72 inches. This would allow a drop ceiling height of 13 feet 10 inches when used with the tall EC Chassis. For ceiling heights above this, you can use a taller rack and/or use the EC Duct Cap that is made to couple with a 20" round duct. This 20" round duct would allow you to go to any ceiling height. See Geist Global's Submittal Drawings for further information.

Q: What types of fans are used in your system? I believe they are DC, but I remember someone asking me a while ago if they were brushless, tube axial, etc.

A: We are using 48V DC Electronically Commutated (EC) fans. Our fans are brushless and have a tube axial configuration.

Q: What is the MTBF of the EC Fans and System?

A: The MTBF is 60K hours for the fan itself, but we conservatively de-rate our system MTBF to 40K hours (4.5 yrs) based on accepted de-rate rules for electronics.

Cooling and Airflow Management

Q: If I lose one fan, will the remaining fan handle the entire rack airflow requirements?

A: If the EC capacity reading is 50% or less when two fans are operational, then one fan is capable of handling the airflow requirements. The single fan will speed up to compensate for the fan that is off line. However, Geist Global does not recommend sizing the EC for airflow redundancy. The additional overhead for fan power, space required and costs are not justified.

The following is what to expect if one fan fails or is removed from the system:

- Capacity for the remaining fan will approximately double or reach 100% if the two fans were originally operating greater than 50%.
- A slight pressure in the rack will force a small amount of hot air leakage out the front rack rails and bottom of the rack due to this pressure. This is common with any passive system and will not cause issues since this should be the only rack with leakage due to no pressure control.
- The EC will send an alarm when a cartridge fails and a new alarm when the capacity exceeds the set capacity threshold.
- The EC Fan Cartridges can be swapped out while the rack is operational.

Q: We would like to reduce the exhaust temperature of the rack; can we adjust the EC Fan Control setting to a negative pressure to accomplish this?

A: Yes, for example, when you are concerned about high heat return to DX CRAC units. We can control the amount of bypass air by simply changing the negative pressure set point. This pressure setting can be changed remotely and alarm thresholds can be set so you know if you have exceeded your desired temperature. Simply change the setting and then chart the performance over time.

Q: We would like to pull in cool air along the sides of network switches; can we adjust the EC Fan Control Settings to a negative pressure to accomplish this?

A: This can be accomplished for small 1U or large core switches.

Example for 1U switches; set the EC unit to -0.006 pressure and open a 2U space at the rack front opposite or just below the 1U switch height. Cool air then enters this space and washes across the 1U switch/s. The 2U open space at the front should be filled with the Opengate Vented 2U Blank Panel which is clearly marked so someone doesn't come along and block up the opening. Adjustment to the negative pressure set points can be made to reduce or increase bypass airflow.

Example for large core switches; with the large core switch/s in a 750mm or 30 inch wide rack, make sure the left vertical rack rail is blocked from air bypassing and make sure the right vertical rail is open to allow bypass airflow. Set the EC unit to -0.006 pressure. Cool air then enters this space and washes across the switch/s. Place a remote temp/humidity sensor at the side intake of the core switch and monitor intake temperatures. Adjustment to the negative pressure set points can be made to reduce or increase bypass airflow.

Q: How do I safely raise my supply air temperature to 22-24 °C (72-76 °F) and not cause an increase in server airflow?

A: Opengate EC systems maintain temperatures at all points in the data center within a few degrees of the supply air temperature. Opengate systems also eliminate back pressure on server airflow to improve server fan efficiency.

Many legacy servers and servers shipping today increase their fan speeds at approximately 26°C (79 °F) to improve server cooling at higher intake temperatures. This can more than double, sometime 10X the server fan power consumption. While increased server fan power actually lowers your PUE metric, the overall power consumption in the data center increases significantly. More advanced energy star servers have fan speeds adjustments based on server internal temperatures. Because of this, server fan energy performance will also be subject to rack pressure since the pressure reduces airflow rates, a resulting increased temperature in the server will develop which the server fans will overcome with increased airflow.

Q: Should raising temperatures in data centers be carried out in a systematic manner to best determine where hot spots may occur and to possibly prevent the risk of shutdown because of high temperatures?

A: Due to possible site specific variables and unforeseen infrastructure conditions, it would be a recommended practice to take a systematic approach to raising supply air temperatures. One client had a '2 degree Tuesday' approach, raising his supply air 2 degrees every Tuesday until he was at 23°C. With the Opengate EC system deployed on a substantial percentage of the IT load, there should be no hot spots or hot air contamination of the cool supply air. Geist Global allows you to safely raise the supply air without contamination and also allows the servers to run at minimum internal temperatures due to zero back pressure, allowing the maximum supply air temperature and maximum efficiency.

Q: If I raise the supply air, how much less time do I have if my cooling plant fails?

A: A published Geist Global study shows that at average loads of 5 kW per rack and conventional hot/cold aisle design you raise the temperature 9 °F every 20 seconds. If we are supplying at 74 °F versus 65 °F we would only have an additional 20 seconds. What we sometimes fail to recognize is that an average of 5 kW per rack with no cooling is a high heat load to continue to dissipate.

Opengate cooling circuit significantly increases the time to adapt to cooling circuit failure. With Geist Global, the hot exhaust air is directed to a ceiling plenum return. Fans in the EC units are on UPS power and fans on the CRAC/CRAH units will start again when the generator comes on line (typically 8-12 seconds). Even without a chiller plant providing cooling, the IT heated exhaust air continues to move into the ceiling plenum, across the CRAC/CRAH coils and across the cold floor, giving additional time during cooling plant failure.

Q: I have multiple racks with exactly the same IT load but one EC system indicates a different capacity, is something wrong?

A: It is quite common to have two racks with the same IT load running at different flow rates – hence a different EC capacity. There are multiple reasons IT equipment can have different airflow rates for the same IT load; intake temperature, chip temperatures and server power supply failure. Check the EC temperature graphs to rule out intake temperature as the cause. It is important to look at temperature intake at multiple rack heights. Often racks at the end of the row can see hot air at the intake – this condition would only exist when all the racks in the data center do not have an EC system on them. If all three reasons mentioned as ruled out, please call customer service.

Q: Why did the EC capacity keep increasing when there is no load in the rack and what should I do about this?

A: The EC system continually adjusts to maintain the set operating pressure. With no load in the rack, the EC system is trying to operate with an infinitely small pressure change. We recommend un-plugging the unit until a load is placed in the rack. In this condition, a small amount of cool air will bypass through the EC units that are off

Software and Controls

Q: I made a mistake on the IP set up, how can I get back to the factory setting?

A: Press and hold the reset button located under the Ethernet port until the red LED indicators both light up solid, then release. A small probe will be required to depress the reset button.

Q: I have been getting nuisance alarms for temperature and capacity, how can I change these?

A: The Opengate EC system ships with predefined alarm thresholds. These alarm setting should be changed to meet your site conditions and requirements.

Q: What SNMP versions do the EC systems support?

A: Versions 1 and 2.

Q: I noticed that some of my data logs had gaps of several minutes up to 2 hours, all at the same time one day. What could have caused this?

A: When EC systems are powered down they do not continue to collect data. Any time the power needs to be interrupted for servicing a cabinet, we suggest that the units' logs be downloaded before removing power so as not to lose any data.

Please note the information contained herein is for informational purposes only. Technical claims listed depend on a series of technical assumptions. Your experience with these products may differ if you operate the products in an environment, which is different from the technical assumptions. Geist reserves the right to modify these specifications without prior notice. Geist makes no warranties, express or implied, on the information contained in this document.

10006301

Geist Americas

1821 Yolande Ave
Lincoln, NE 68521 USA
1.800.432.3219 or
1.402.474.3400
www.geistglobal.com

Geist DCiM
2290 E Prospect Rd.
Fort Collins, CO 80525
USA
1.877.449.4150
www.geistglobal.com

Geist Europe

Unit 1, The Monarch Centre,
Ventruue Way,
Priorswood, Taunton,
Somerset, TA2 8DE UK
+44 (0) 1823 275100
www.geisteurope.com

Geist Asia

| | |
|--|---|
| China Tiley Plaza, Unit #2808, No. 199 Haide 3 Road Nanshan Shenzhen Guangdong Province China Postal Code: 518000 Tel: +86.755.86639505 www.geistglobal.com | Hong Kong Tel: +852 90361927 Email: salesasia@geistglobal.com www.geistglobal.com |
|--|---|