

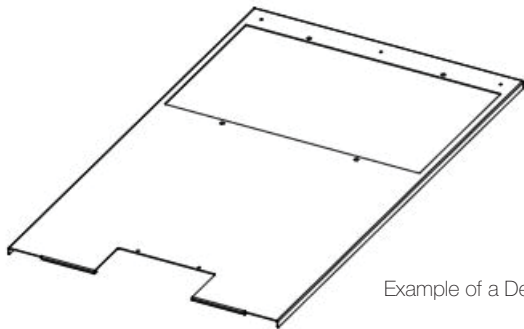

### Rack Conversion Kits

Rack Conversion Kits for Containment Cooling developed and supplied by Geist Cool- Maximize efficiency and IT flexibility while providing a perfectly controlled IT environment.



Example of a Dell Top Panel

**The Geist Containment Cooled data center** stabilizes IT intake air temperature to within a few degrees of the supply air temperature at all points in your data center. Control your thermal environment with one cooling system and manage data center cooling for all IT equipment types, including side airflow network switches and high exhaust temperature servers.

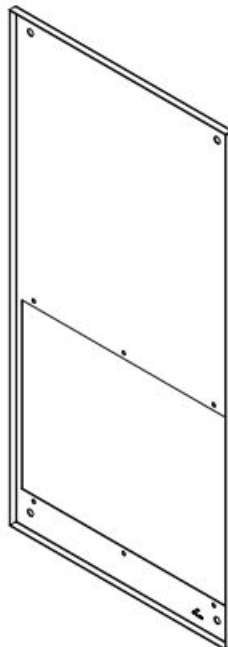

Example of a custom rack

### Why Choose Geist Cool?

Stabilize your IT intake air temperature to within a few degrees of the supply air temperature at all points in your data center.

Reduce total data center fan power consumption and improve server fan efficiency.

Adjust cool air delivery to IT demand as airflow demand dynamically changes.

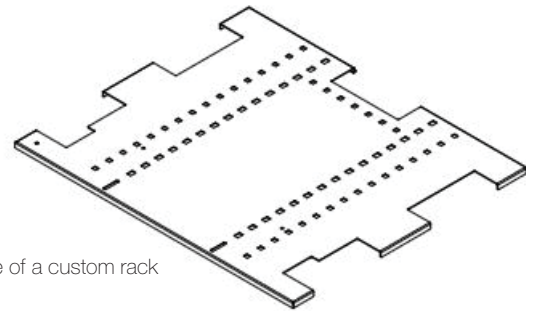

Example of a custom rack

“We’re putting Geist Cool on all new racks coming into our high-density area.”  
- Mitch Martin, Oracle Chief Engineer

**Rack Conversion Kits (RCK) are available for:**

- Retrofitting data centers for Containment Cooling.
- A new build when rack manufacturers are unable to supply solid rear doors and/or top panels per Geist template.

**Versatile For All IT Equipment**

Cool ultra-efficient servers designed closer to their thermal limits, even multiple large network switches places in a rack. Auto-scale to server flow rate, including side-flow network switches and high temperature exhaust servers with variable flow rates.

**No Supplemental Cooling**

Eliminate the need for supplemental cooling, allow fewer cooling units, and keep water/Glycol at the facility perimeter. Cooling unit redundancy is applied to the entire data center space, not at the row level.

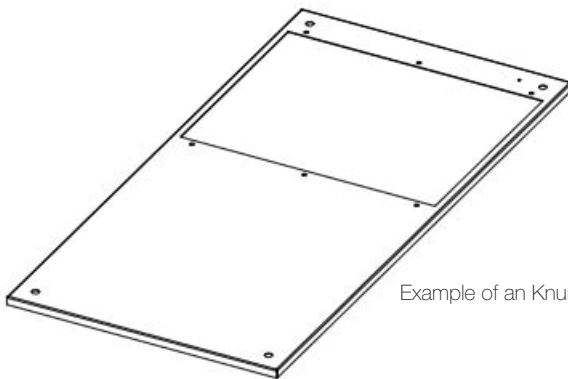

Example of an Knurr Lid

**Ultra-Efficient Cooling**

Achieve 100% cooling utilization for zero-waster cooling and the lowest PUE.

- Raise supply air temperature
- Raise entering water temperature
- Maximize free cooling hours

Deploy more IT racks without heat issues and intelligently manage data center growth.

Achieve full data center loading with Geist Containment Cooling.

**Build with Confidence**

Why adjust to hot spots when you can normalize your entire data center?

Achieve Unity Cooling and Maximize free Cooling:

- Supply air at 76F
- Intake air less than 78F

Maximize Rack and Room Density and Achieve Best-In-Class PUE:

- Zero Cooling Waste
- Zero Heat Issues

**Deploy More IT with Confidence**

- ...In Data Centers
- ... In Racks
- ...In Small Spaces

“Geist containment systems enabled AAFC to quickly meet aggressive growth demands on data center services.”

- Eric Swanson, Agriculture & Agri-Food Canada

**Geist Americas**

800.432.3219  
geistglobal.com

Geist DCIM  
1.877.449.4150  
geistglobal.com

**Geist Europe**

+44 (0) 1823 275100  
geisteuropa.com

**Geist Asia**

China  
+86.755.86639505  
geistglobal.com

Hong Kong  
+852 90361927  
geistglobal.com