

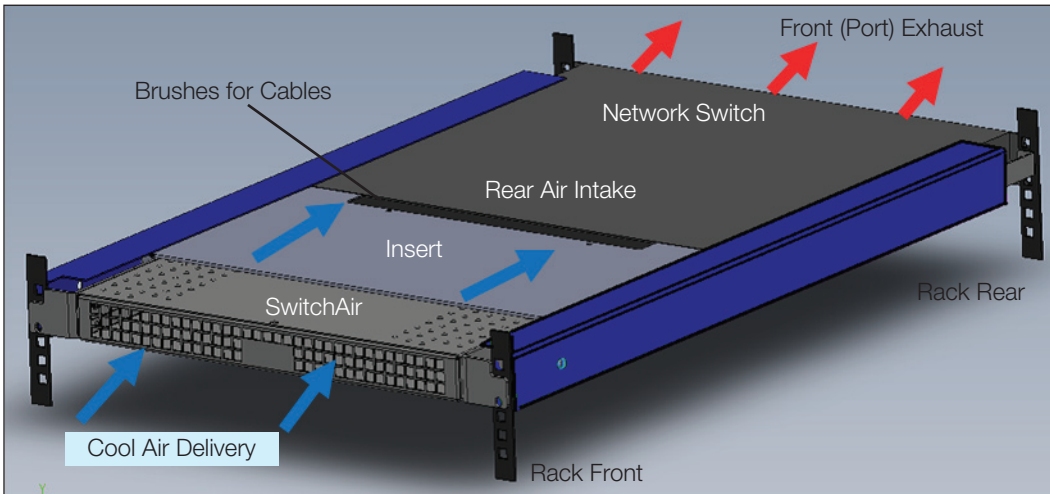

SA1-01002XLNB SwitchAir

For Rear Air Intake-Front (Port) Exhaust Switches



Delivers cool air to network switches with rear air intake and front (port) exhaust. Installs in minutes while network switch is live.

SA1-01002XLNB Specification	
Rail Depth	28 ½" to 30"
Chassis / Extender Depth	12 ¾" to 21"
Airflow	Switch Generated (Passive)
Switch Intake/ Exhaust	Rear/Front
Warranty	Lifetime
XLNB Option Includes	Extra Long Insert with New Build Side Rails

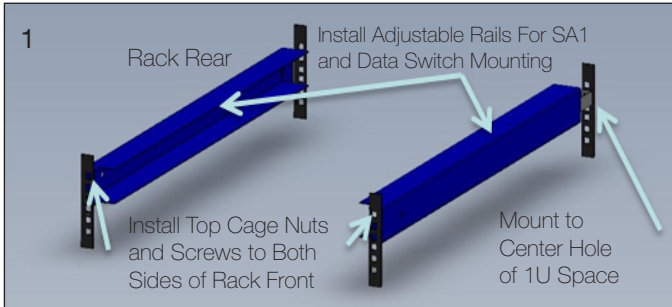

STEP 1 Mount the adjustable rails using customer provided cage nuts and screws. The new build rails will be used to support the network switch, SwitchAir chassis and insert. Attach the new rails using only the top front screw holes on both rack front rails. The rail extension tab attaches to the rack rear using a single cage nut and screw. Use the center hold of the 1U space for this attachment.

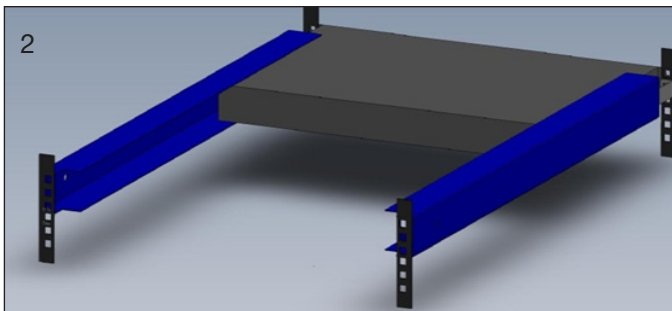

STEP 2 Slide the network switch into the rails and mount to the rack using customer provided cage nuts and screws.

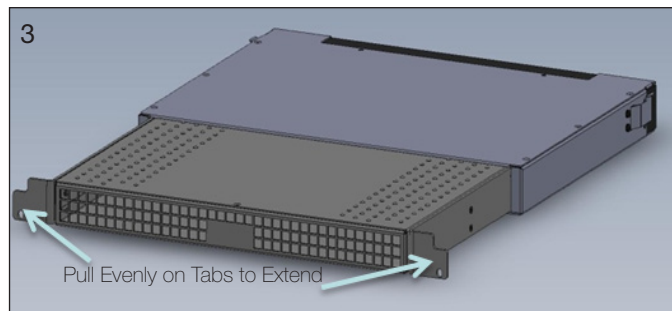

STEP 3 SwitchAir is not in the fully extended position when shipped from the factory. Pull evenly on the chassis mounting tabs for the desired depth.

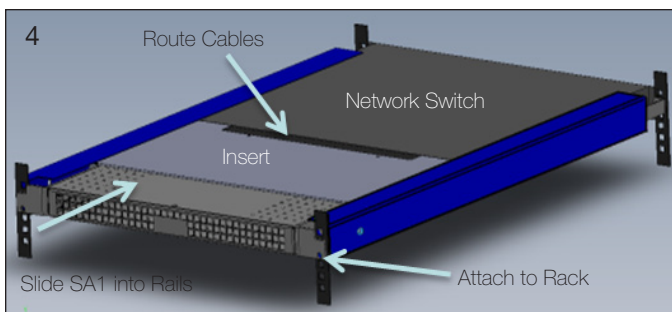

STEP 4 Insert SA1 into the rails and push unit until the insert comes into contact with the network switch and the chassis tabs are in contact with the rack. During this process route the cables through the brush openings. Install the bottom SA1 chassis screws on both sides.

Install is complete.



10001501

Geist Americas

800.432.3219
geistglobal.com

Geist DCiM
1.877.449.4150
geistglobal.com

Geist Europe

+44 (0) 1823 275100
geistglobal.com

Geist Asia

China
+86.755.86639505
geistglobal.com

Hong Kong
+852 90361927
geistglobal.com